



**VIC Leak Detection**  
Industrial Leak Detection

# **MD-490S PORTABLE HELIUM LEAK DETECTOR**



**OPERATION MANUAL**

**TABLE OF CONTENTS**

**SECTION 1.0 – SYSTEM COMPONENTS ..... 1**

    1.1 MASS SPECTROMETER TUBE..... 1

    1.2 ION SOURCE ..... 1

**1.3 MAGNET ..... 2**

    1.4 COLLECTOR AND AMPLIFIER..... 2

    1.5 VACUUM PUMPS ..... 2

    1.6 FORE-PUMP..... 2

    1.7 TURBO-MOLECULAR PUMP..... 2

    1.8 TURBO PUMP POWER SUPPLY MODULE..... 3

    1.9 BALLAST PRESSURE SENSOR ..... 3

    1.10 GAS SAMPLING SYSTEM ..... 3

**1.11 FIXED ORIFICE..... 3**

    1.13 PROBE VALVE..... 4

    1.14 HELIUM LEAK STANDARD (P/N 752-150) ..... 4

    1.15 SYSTEM CYCLING DESCRIPTION..... 4

    1.16 Console Control Panel P/N 656-190 ..... 4

**1.16.1 “START UP” KEY..... 5**

    1.16.2 “SHUT DOWN” Key ..... 5

    1.16.3 “FIL ON/ OFF” Key..... 5

    1.16.4 “CAL” Key ..... 5

**1.16.5 “FIL A/ FIL B” KEY ..... 6**

    1.16.6 “STBY” Key..... 6

    1.16.7 “MENU” Key ..... 6

**1.16.8 “DIAG” KEY ..... 9**

    1.16.9 “VOL” Key..... 10

    1.16.10 “AUTO RANGE” Key..... 10

    1.16.11 Arrow up Key ..... 10

    1.16.12 Arrow down Key ..... 10

    1.16.13 “TEST/ STOP” Key ..... 10

    1.16.14 “ZERO” Key ..... 11

    1.16.15 “LOCKOUT” KEY ..... 11

**MANUAL- MD-490S PORTABLE HELIUM LEAK DETECTOR**

**SECTION 2.0 - OPTIONAL EQUIPMENT ..... 12**

- 2.1 EXTERNAL CALIBRATED GAS LEAK ..... 12
- 2.2 OPTIONS ..... 12
- 2.3 HELIUM CHARGING STATIONS ..... 13
- 2.4 VIBRA-PROBE ASSEMBLY KIT: 912-109 FOR THE VIBRA PROBE OPTION..... 13

**SECTION 3.0 - PORTABLE HELIUM LEAK DETECTOR UNIT SPECIFICATIONS..... 14**

- 3.1 PERFORMANCE..... 14
- 3.2 SPECTROMETER TUBE..... 14
- 3.3 VACUUM SYSTEM..... 14
- 3.4 ELECTRICAL..... 14
- 3.5 POWER REQUIREMENTS ..... 15

**SECTION 4.0 - INSTALLATION AND OPERATION ..... 16**

- 4.1 UNCRATING..... 16
- 4.2 SYSTEM START-UP ..... 16
- 4.3 SENSITIVITY CHECK/SYSTEM TUNING ..... 17
- 4.4 COMMENTS ON LEAK LOCATION..... 17

**SECTION 5.0 – SHUTDOWN PROCEDURE ..... 18**

- 5.1 TEMPORARY/OVERNIGHT SHUT-DOWN (STAND BY MODE)..... 18
- 5.2 COMPLETE SHUT DOWN OF SYSTEM ..... 18

**SECTION 6.0 – GENERAL MAINTENANCE..... 19**

- 6.1 MAINTENANCE SCHEDULE..... 19
- 6.2 INDICATIONS OF A CONTAMINATED VACUUM SYSTEM..... 19

**6.3 GENERAL REMARKS ON CLEANING PROCEDURES..... 20**

- 6.3.1 Vacuum System..... 20
- 6.3.2 Gaskets ..... 20
- 6.3.3 Solvents ..... 21
- 6.4 MAINTENANCE OF THE VACUUM SYSTEM ..... 21
- 6.5 MASS SPECTROMETER TUBE..... 21
- 6.5.1 Source Removal/Installation for Filament Plate Replacement..... 21
- 6.5.2 Collector Removal/Installation..... 23
- 6.5.3 Magnet Removal/Installation:..... 25
- 6.5.4 Removal/Installation of Complete Spectrometer Tube ..... 25

**MANUAL- MD-490S PORTABLE HELIUM LEAK DETECTOR**

6.6 VACUUM SYSTEM MAINTENANCE ..... 26

6.6.1 Turbo-molecular Pump Removal/Installation ..... 26

6.6.2 Turbo Pump Lubricant Reservoir Replacement ..... 28

6.6.3 Fore-pump Removal/Installation ..... 29

6.6.4 Fore-pump Membrane Head change. .... 29

6.6.5 Vacuum Manifold Removal Procedure ..... 31

6.6.6 Orifice Replacement ..... 31

6.6.7 Manifold Disassembly Procedures ..... 32

6.6.8 VACUUM REGULATOR REPLACEMENT AND ADJUSTMENT: ..... 33

6.6.9 BALLAST PRESSURE TRANSDUCER REPLACEMENT AND ADJUSTMENT: ..... 34

**6.7 ELECTRONIC ASSEMBLIES ..... 35**

6.7.1 Main Power Supply Removal/Installation ..... 35

6.7.2 PC Board Removal/Installation ..... 36

**SECTION 7.0 – SYSTEM SOFTWARE ..... 38**

7.1 KEYPAD MENU AND DIAGNOSTIC FUNCTIONS ..... 38

7.2 MENU #1 FUNCTIONAL DIAGRAM ..... 39

7.3 MENU #2 FUNCTIONAL DIAGRAM ..... 40

7.4 MENU #3 FUNCTIONAL DIAGRAM ..... 42

7.5 MENU #4 FUNCTIONAL DIAGRAM ..... 43

7.6 DIAG FUNCTIONAL DIAGRAM ..... 44

**SECTION 8.0\_TROUBLE SHOOTING ..... 46**

SOLUTION 46

**SECTION 9.0 – RECOMMENDED SPARE PARTS ..... 49**

**SECTION 10.0 – BILL OF MATERIALS ..... 50**

**APPENDIX 1- COMMUNICATION OPTION ..... 53**

**APPENDIX 2- LEAK RATE ANALOG OUTPUT OPTION ..... 58**

**APPENDIX 3 - REMOTE I/O OPTION ..... 60**

**NOTICE ..... 62**

## SECTION 1.0 – SYSTEM COMPONENTS

The **MD-490S PORTABLE HELIUM LEAK DETECTOR** is a Helium leak detection instrument that uses a **MASS SPECTROMETER** sensing device and a continuous gas sampling method.

This instrument is capable of detecting and qualifying Helium leak rates in the range of  $10^{-8}$  to  $10^{-3}$  atm-cc/sec using the accepted methods of pressure leak testing. The most notable features of the instrument include automatic start-up/shutdown, Auto-ranging, Auto-Calibration, Probe Blocked Feature, coupled with simplicity in design and ease of maintenance.

### 1.1 MASS SPECTROMETER TUBE



P/N: 751-112

The heart of the **MASS SPECTROMETER LEAK DETECTOR** is the **MASS SPECTROMETER TUBE**. All other components of the **LEAK DETECTOR** function to create, control, measure and maintain optimum operating conditions for this device. It is within the **SPECTROMETER TUBE** that the Helium tracer gas is ionized, focused, accelerated, deflected, collected and finally transformed into a visual indication on the **LED BAR GRAPH DISPLAY**.

The **SPECTROMETER TUBE** may be divided into three major sections, each performing a distinct function and yet all contributing towards the detection of small quantities of Helium. These three sections are:

### 1.2 ION SOURCE



P/N: 651-132

When the gas sample from the object under test enters the **mass SPECTROMETER TUBE**, it first passes into the source region where the gas is subjected to a beam of electrons. The electron beam is produced from a coated thoria iridium filament, which is heated by passing an electric current through it. As the electron beam bombards the incoming gas sample, electrons, which collide with the gas molecules, cause them to become ionized.

These positive ions are collimated and accelerated out of the source assembly into a conical shaped beam. Since gas entering the tube consists of several element constituents, so will the ion beam contain several kinds of ions, such as nitrogen, oxygen, hydrogen, carbon dioxide and if a leak is encountered, Helium.

### 1.3 MAGNET

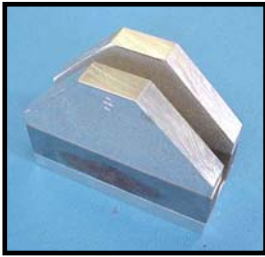

P/N: 751-104

A 90 degree fixed magnet, which is mounted external to the vacuum system, separates the Helium ions from all other ions in the beam.

The effect of the magnetic field is to deflect the path of the positive ions. The degree of deflection is determined by the weight of the particles. Therefore, the ion beam, which contains several types of different mass ions, will be segregated into a spectrum of separate beams, each of which contains only ions of the same mass. Heavy ions, such as nitrogen and oxygen are deflected less than other lighter ions, such as hydrogen.

NOTE: "S" STAMPED ON THE FIXED MAGNET INDICATES SOUTH-POLE MOUNT TOWARDS SPEC-TUBE HI-VAC FLANGE.

### 1.4 COLLECTOR AND AMPLIFIER



P/N: 651-302

The deflected Helium ions, upon their exit from the magnetic field travel into the collector region of the SPECTROMETER TUBE. Here, the ions strike the target, or collector plate, and give up their charge. The collector plate is connected to the input of a high gain amplifier module, which is located within the SPECTROMETER TUBE. The amplified signal is proportional to the size of the leak in the object being tested. The signal generated from the amplifier module is a voltage which is filtered and scaled to  $\pm 10$  VDC. This voltage through an analog drives the LED BAR GRAPH to digital converter. The MD-490S is designed so that the system displays the actual leak rate of the product under test.

### 1.5 VACUUM PUMPS

Two vacuum pumps are provided which work in conjunction to reduce the total pressure in the system to less than  $10^{-5}$  Torr. The MD-490S PORTABLE LEAK DETECTOR uses a hybrid turbo molecular pump (part# 353-691-1015) and a diaphragm pump (part# 631-117).

### 1.6 FORE-PUMP

The fore-pump in the MD-490SD is a diaphragm type pump capable of reducing system to less than 5 Torr. The diaphragm pump is oil free and extremely quiet with noise levels approximately 52dB (A). The lack of an oil mist exhaust makes for an environmentally friendly pump.

### 1.7 TURBO-MOLECULAR PUMP

Since the vacuum produced by the fore-pump is not sufficient for proper operation of the mass SPECTROMETER TUBE, a hybrid turbo molecular pump is also employed (part# 353-691-1015). The hybrid turbo pump is capable of high exhaust pressures and will reduce system pressure below  $10^{-5}$  Torr.

The Turbo-molecular pump (hybrid) uses an axial blade turbine that compresses gas by momentum transfer from high-speed rotation. The turbo pump rotor operates at 45,000 rpm using a number of angled blades. These blades are interlaced with stator blades whose angles are diametrically opposed. The relative velocity between the rotor and the stator forces gas molecules from the inlet to exhaust port. The fore-pump then exhausts the gas to atmosphere. The turbo pump is configured to operate at a frequency of 750Hz. (+ or - 5 ).

### **1.8 TURBO PUMP POWER SUPPLY MODULE.**

The electronic drive module controls and monitors the turbo pump and is mounted directly to the turbo pump. The electronic drive unit has two LED that give information about pump operation. Turbo Pump speed is factory set at 50% 45,000 rpm in standard operation, the green LED should always be on. During start up the green LED with flash.

### **1.9 BALLAST PRESSURE SENSOR**

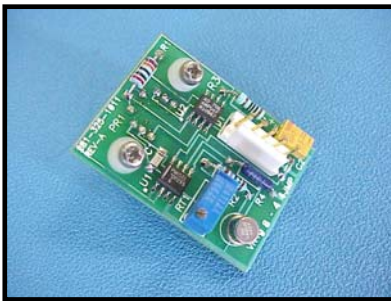

The BALLAST BOARD pressure sensor, located on the manifold, monitors manifold pressure. This sensor detects changes in sniffer probe gas flow and compares it to an operator-programmed set point. If the probe becomes clogged or if pump operation changes, this sensor will detect a pressure change. If the change exceeds the BALLAST PRESSURE SET POINT an audio/ visual alarm is issued.

P/N 584-335

### **1.10 GAS SAMPLING SYSTEM**

The LEAK DETECTOR system utilize a unique gas sampling system, which by design greatly enhances the ability of an operator to quickly pinpoint leak location. The systems consist of a vacuum regulator, fixed orifice, and a sniffer probe transport system. The secondary stage vacuum produce by the fore-pump is utilized to draw the gas sample from the probe to the fixed orifice. As the sample enters the orifice any Helium present in the sample passes through and is detected by the mass SPECTROMETER TUBE.

### **1.11 FIXED ORIFICE**

The orifice allows the mass spectrometer LEAK DETECTOR high vacuum system to remain at proper working pressure ( $1 \times 10^{-5}$  Torr) for high sensitivity while atmospheric pressure is present at the sniffer probe. The secondary stage of the fore-pump is utilized to draw the sample from the probe to the orifice.

### 1.12 SNIFFER PROBE TRANSPORT SYSTEM

The sniffer probe sample transport system operates in the laminar flow range. The approximately flow through the probe is 200 cc/min. The stream line motion flow through the sniffer allows greater Helium sampling coupled with fast Helium response into the mass SPECTROMETER TUBE (a response time of less than 0.5 seconds).

### 1.13 PROBE VALVE

The probe valve is a solenoid operated valve, which exposes the sniffer port to the fixed orifice. This is a NORMALLY OPEN valve, which exposes the gas sample from the test object into the high vacuum system, through the fixed orifice.

### 1.14 HELIUM LEAK STANDARD (P/N 752-150)

A standard VIC Calibrated Gas Leak is mounted inside the unit. It is connected directly to an external port and is used for system calibration. **Note: VIC recommends that the Helium standard be re-calibrated annually P/N for recalibration 924-395**

Calibration to the provided NIST traceable helium leak standard should be performed once per operating shift. Performing calibration maintains the relative SPECTROMETER TUBE sensitivity. **See section 1.16.4 for the unit calibration procedure.**

A frequent probing of the internal gas leak to is a quick test that will ensure that the unit is within calibration. VIC recommends that a sensitivity check be performed every 2 hours .

### 1.15 SYSTEM CYCLING DESCRIPTION

In normal operation, the high vacuum section of the system is maintained at a pressure of approximately  $1 \times 10^{-5}$  Torr by the combined pumping action of the turbo and Fore-pump. To test a product, it must be back-filled or pressurized with Helium. The product is then checked for a possible leak. The operator utilizes the sniffer probe to probe the product's seams, joints, and other areas that are in question or have the possibility of leaking. Leak test sniffing should be done at a rate of **1" per second and a distance no greater than 1"** from the part surface. As the gas samples pass through the sniffer transport system and into the high vacuum section the scaled leak rate is displayed proportionally to the signal detected by the mass spectrometer.

### 1.16 Console Control Panel P/N 656-190



The console control incorporates the following controls and indicators:



### 1.16.1 “START UP” Key

The start up key is the green key located on the upper right hand corner of the control panel. Once the Start-Up key has been pressed, the unit will begin an automatic start-up sequence.

### 1.16.2 “SHUT DOWN” Key

The system will automatically go into a shutdown routine when this key is pressed. The routine consists of de-energizing the PROBE VALVE, the SPECTROMETER TUBE filaments, the fore-pump and the turbo pump. Pressing this key disables the system in preparation for power down.

### 1.16.3 “FIL ON/ OFF” Key

When pressed, the associated LED illuminates to indicate that a filament is ON, A or B. If this LED is blinking, it is an indication that the current filament is non-operational, the probe is blocked, there is a gain error or the unit is in standby. The operator can switch to the alternate filament using the FIL A or FIL B key. The filament is slow started to prevent excessive heating. This key function can be locked out using the LOCKOUT KEY (see section 1.16.15 for LOCKOUT Key explanation).

Turning the filaments on or switching the filaments will RAMP the filament current up from zero amps. The filament current will not exceed an internal current limit of 4 amps. The display will indicate when the filament current is ramping up.

**NOTE: WITHOUT THE SPECTROMETER TUBE FILAMENT OPERATING, NO HELIUM DETECTION IS CAPABLE.**

### 1.16.4 “CAL” Key

The calibration procedure guides the operator through a series of steps. To start a calibration cycle, the machine must be in the TEST MODE with the filaments ON.

1. Pressing the CAL. key prompts the operator to clear the PROBE, by locating the probe away from any possible Helium leak source or leaks.
2. Prompts the user to insert the probe into the calibrated leak when the auto-zero completes.
3. Another key press displays the CALIBRATED LEAK value and performs an AUTO CAL by adjusting the gain until the leak rate output corresponds with the programmed value for the gas leak standard. If the system is unable to successfully calibrate the unit a GAIN FAULT will be displayed. **See Section 8.0 troubleshooting**

The CALIBRATOR value can be changed in MENU #2. This value must be equal to the leak standard that the calibration is being performed to. This key function can be locked out using the LOCKOUT KEY. Note after the probe has been installed into the calibrated gas leak, allow time for the leak rate to stabilize before pressing the “CAL” Key.

### 1.16.5 "FIL A/ FIL B" Key

When pressed, the selected filament is turned ON and the corresponding LED indicator is illuminated. The current is ramped up to prevent heat damage to the filament due to surging.

This key function can be locked out using the LOCKOUT KEY.

Turning the filaments on or switching the filaments will RAMP the filament current up from zero amps. The display will indicate when the filament current is ramping up. The filament current limit is set to 4 amps maximum, with a nominal value of approximately 2.5 amps.

**NOTE: ONLY ONE FILAMENT IS ENERGIZED AT ANY ONE TIME. WHENEVER A FILAMENT IS CHANGED, AN AUTO CALIBRATION SHOULD BE DONE TO COMPENSATE FOR POSSIBLE DIFFERENCES IN FILAMENT SENSITIVITIES.**

### 1.16.6 "STBY" Key

The STBY key is used to place the unit in an inactive mode. The filaments are turned OFF, the display blanked, the probe valve is closed and the TEST/ STOP LED will blink. This mode is used for idle periods of 2 hours or more, where a quick restart is required. This mode is also ideal for an overnight period. Pressing any key again will return the unit to the TEST or STOP MODE.

### 1.16.7 "MENU" Key

When pressed, the MENU LED will illuminate indicating access to the following functions:

Note Standard units require the key unlocked to permit adjustments. See SECTION 7 for menu outline.

**MENU #1, SENSITIVITY:** Permits access to change the EMISSION, GAIN and MANUAL TUNING parameters required to vary the unit sensitivity. The dynamic digital leak rate is displayed at each of these parameter settings. See section 7.2 for functional diagram.

**EMISSION:** When accessed, the electron emission can be adjusted using the UP and DOWN arrow keys.  
Increasing the emission will increase the sensitivity due to higher amounts of ionized gas. Ideally, the emission should be between 0.5 to 2.0 milliamps.

**MANUAL TUNE:** When accessed, the tune voltage can be adjusted using the UP and DOWN arrow keys, this can be done while sampling the internal gas leak. The ideal tune voltage is reached when maximum deflection is observed on the leak rate bar graph.

**GAIN:** When accessed, the system gain can be adjusted using the UP and DOWN arrow keys. With the probe sensing the CALIBRATED LEAK PORT, observe the LED BAR GRAPH while adjusting to obtain the CALIBRATED LEAK VALUE. This function is done automatically when the CAL function is performed and will override any value pre set by the user.

**MENU #2, SYSTEM SETUP:** This menu allows the following items to be set. See section 7.3 for functional diagram

**PROBE BLOCKED PRESSURE:** The probe-blocked pressure is the set-point at which a probe blocked fault will be indicated. When the probe is blocked, the flow decreases, resulting in a decrease in ballast pressure. This can occur, if either of the (2) probe filters or the sniffer probe tubing become clogged.

To set the threshold (system should be in TEST MODE) view the BALLAST PRESSURE within the DIAG MENU. Set the PROBE BLOCKED PRESS. Set-point within the MENU #2 approximately 50 Torr or 6.9 kPa below the indicated pressure.

**Example:**

If the unblocked ballast pressure is 200 Torr, set the threshold to 150 Torr. If the ballast pressure is 25.5 kPa set the threshold to 18.6 kPa. To test, place a finger over probe tip to block the flow. Fault indication should be displayed when the actual pressure reaches the set-point value.

**Set Point Function:**

The Set Point menu function allows the user to establish two (2) threshold data points for leak rate detection. These are ideal for go/no-go testing applications. This function is available from the MENU #2. Reject status is indicated on the top half of the display. REJ#1 appears in the left corner if the leak rate exceeds set-point #1. REJ#2 appears in the right corner if the leak rate exceeds set-point #2. Both set-points can be changed in MENU #2, SYSTEM SETUP.

**SET-POINTS ON/OFF:** At this menu selection, use the ENTER key to enable or disable set-points function. The reject prompts (REJ#1 or REJ#2) will only be displayed if this function is enabled.

**SP#1 AND SP#2:** At this menu selection, use the “ENTER” and ARROW keys to change these values. Insure that the key lockout is disabled. Pressing the “ENTER” key stores the current digit value and scrolls the cursor to the next digit.

**CALIBRATED LEAK:** At this menu selection, use the “ENTER” and ARROW keys to change the CALIBRATED LEAK VALUE. The entered value must match the CALIBRATED LEAK VALUE for proper system calibration. **This value must be manually changed every time the gas leak is replaced.** When calibrating the gain will automatically be adjusted so the display reads the programmed value for the gas leak. **See section 1.16.4.**

**LEAK RATE DISP. ON/OFF:** At this menu selection, use the “ENTER” key to toggle the display on and off. When OFF, the only indication of leak rate will be the LED BAR GRAPH. When ON, the digital leak rate is displayed in the center of the alphanumeric display. The digital leak rate can be displayed in GM/YR, Pa M3s, CC/SEC or OZ/YR. See SECTION 7.3

**AUDIO MODE SELECTION:** Two audio modes are available. Use the "ENTER" key to select mode 1 or mode 2.

**MODE 1**

A continuous tone is sounded as soon as the reject set point #1 is exceeded. Pitch is directly proportional to leak rate value and continues to increase as the leak rate bar graph range increases.

**MODE 2**

A continuous tone is sounded corresponding directly to the LED BAR GRAPH mantissa. The lowest audio tone corresponds to the mantissa of the set point. Pitch is directly proportional to leak rate value. If the Auto-Range feature is enabled, the pitch varies exactly for each new decade.

**SELECT UNITS:** The units used for the set-point values can be changed between PA M3S, CC/SEC and OZ/YR. Use the Enter key to choose the desired units. Factory defaults is CC/SEC. See SECTION 7.2

**RECALIBRATE ALARM:** At this menu selection, use the arrow keys to set the RECALIBRATE WATCHDOG ALARM. This alarm is used to prompt the operator to auto-calibrate. The alarm timer can be set from 1 to 99 hours. To disable, set the timer to less than 1 hour.

**TURBO SPEED:** The frequency that determines the rate at which the turbo pump is operating. Factory set to 750 Hz + or- 5 45,000 rpm. The speed can be changed by adjusted the frequency using the up/down arrow keys. Changing the turbo speed will drastically effect the unit’s ability to accurately measure and quantify leaks.

**PRESSURE UNITS:** The ballast pressure can be displayed in either torr or kPa.  
760 torr = 101.325 kPa

**ZERO SUPPRESS:** Zero Suppression automatically adjusts the leak rate display to compensate for negative background. For program revision 01 or higher this feature can be turned off via the menu function. In addition 01 and higher zero suppression only operates when sniff is enabled.

**MENU #3, OPTIONS:** The following options can be checked for their current status, ENABLED or DISABLED and the program revision can also be viewed. An option is enabled at the factory or by changing the program EPROMS. See section 7.4 for functional diagram. When ordering options for existing units please specify the unit S/N, current program version and if there are any options already enabled. See section 2.2

**COMMUNICATION:** Displays the COMMUNICATION OPTION status.

**LEAK RATE ANALOG OUT:** Displays the LEAK RATE ANALOG OPTION signal status.

**REMOTE I/O:** Displays the REMOTE I/O OPTION status.

**PROGRAM VERSION:** Displays the PROGRAM VERSION name.

**MENU #4, RESET HOURS:** The accumulated hours for the following components can be reset by pressing the ENTER key at each sub-menu selection. The components are, in order, TURBO PUMP, FILAMENT-A, FILAMENT-B and the FORE-PUMP. See section 7.5 for functional diagram.

Adjustment to the hour reset function can be locked out using the LOCKOUT KEY.

### 1.16.8 “DIAG” Key

When pressed, the DIAG LED will illuminate indicating access to the following system parameters (this is used for diagnostics only, no adjustments allowed):

TURBO PUMP, FORE-PUMP RUNNING HOURS,	BALLAST PRESSURE, SET-POINT
FILAMENTS A & B RUNNING HOURS,	COLLECTOR, S-PLATE VOLTAGE
TUNE, STF, A PLATE, C PLATE,	TURBO SPEED, BOARD TEMPERATURE
EMISSION, FILAMENT CURRENT,	FILAMENT A AND B GAIN

### 1.16.9 “VOL” Key

When pressed, this key will allow changing of the audio alarm volume, To adjusted use the UP and DOWN keys to a comfortable listening level. To enable or disable the audio alarm press the volume key twice e until the prompt is displayed then press enter. The audio must be enabled in order for the volume control adjustment to function.

### 1.16.10 “AUTO RANGE” Key

When pressed, this key toggles auto range function ON or OFF. Auto range is enabled when the led is illuminated. Auto range automatically selects the correct sensitivity decade for the leak display. If a large leak is detected the display down ranges to a low sensitivity scale. For small leaks, the most sensitive scale is automatically selected.

There are two methods of choosing a leak rate range, manual or auto.

- a) Use the RANGE UP or RANGE DOWN key to adjust the display sensitivity setting. Test Range is  $10^{-8}$  to  $10^{-3}$  Atm-cc/sec.
- b) Press the AUTO RANGE key to enable the AUTO RANGE function. The Auto-Range LED will illuminate, indicating that the AUTO RANGE function is enabled. To disable the AUTO RANGE function, press the AUTO RANGE key again.

### 1.16.11 Arrow up Key

This key is used in conjunction with the other function keys to increment a display value.

### 1.16.12 Arrow down Key

This key is used in conjunction with the other function keys to decrement a display value.

### 1.16.13 “TEST/ STOP” Key

When pressed, this key toggles the probe valve to open and close, prompting the TEST and STOP mode respectively. The TEST mode is the normal operation mode and will illuminate the LED. The STOP function will terminate the TEST mode and, disable the LED.

**1.16.14 “ZERO” Key**

The zero key is utilized to zero out ambient Helium. This is achieved by sampling the current ambient helium level and off setting the current collector output so the leak rate displays zero. This feature allows a known reference starting point when conducting go/no go leak test to a specific reject set point. The led will blink once indicating auto zero. **See section 2.4 for the optional Helium Background Suppression option:**

- a) To Auto Zero, press the Zero key.
- b) To manually zero the display, press and hold either the UP or DOWN ARROW key. While holding an arrow key, press the ZERO key at the same time and hold. This will place the system leak rate level at the exact value it is left in.

**1.16.15 “LOCKOUT” Key**

This key is located on the bottom half of the front display of the unit. The key locks all critical options that are adjustable through the menus as well as the calibration function and turning ON/OFF of the filaments.

**Note: VIC offers optional programs that can be customized to allow access to the standard factory restricted functions. Please contact our sales department for details.**

SECTION 2.0 - OPTIONAL EQUIPMENT

2.1 EXTERNAL CALIBRATED GAS LEAK

Glass and metal orifice leaks are calibrated to specifically match your products reject point. Used as an added check, towards the machine performance and as a master reject leak standard for your product. (i.e.  $1.8 \times 10^{-5}$  Atm-cc/sec)

2.2 OPTIONS

**Remote Box option:**

This option provides remote monitoring and control functions using a hand held remote box. The remote box is connected to the front panel port using a fifteen (15) ft. industrial coiled cord. The remote box contains the following controls and indicators:

ILLUMINATED LED BAR GRAPH and EXPONENT  
TEST/ STOP KEY/ LED  
ZERO KEY/ LED  
RANGE UP/ KEY/ LED  
RANGE DOWN KEY

**VIC PART NUMBER: 918-100**

**PLC Interface (AC or DC):**

For use with PLC type devices. Remote I/O for start/stop, zero, set point #1 and leak detector ready.

**VIC PART NUMBER: 918-508 for AC or 918-507 for DC**

**Analog output option:**

This option provides an analog output of the leak rate using the ANALOG rear panel port to interface to an external meter or Programmable Logic Controller.

**VIC. PART NUMBER: 918-504**



**Communication option:** This option provides complete remote monitor and control of the unit using the RS232 rear port and a standard RS-232 serial interface to a remote ASCII terminal. See APPENDIX 1., COMMUNICATION OPTION in this manual for a complete explanation.

**VIC PART NUMBER: 918-501**

### 2.3 HELIUM CHARGING STATIONS

This unit can be configured to fit a range of Helium charging requirements. Vacuum Instrument Corp., also offers complete test booth setups incorporating fixturing, fittings, Helium gas charging and recovery.

### 2.4 VIBRA-PROBE ASSEMBLY KIT: 912-109 FOR THE VIBRA PROBE OPTION 658-105 FOR THE VIBRA PROBE REPLACEMENT

The patent pending Vibra-Leak Probe with background suppression button provides tactile feedback when leak rate exceeds the reject set point; Ideally suited for noisy environments where audio alarms cannot be heard or where leak detectors are in close proximity. Vibra probe solves background problems during the test.

**Helium Background Suppression:** With a push of a button, the MD 490-S eliminates the background. The MD 490 S suppression feature automatically corrects for changes in the ambient helium levels and prevents the leak rate from dropping below zero within the user selectable test range. This option is ideally suited for test areas where helium background levels are continually changing.

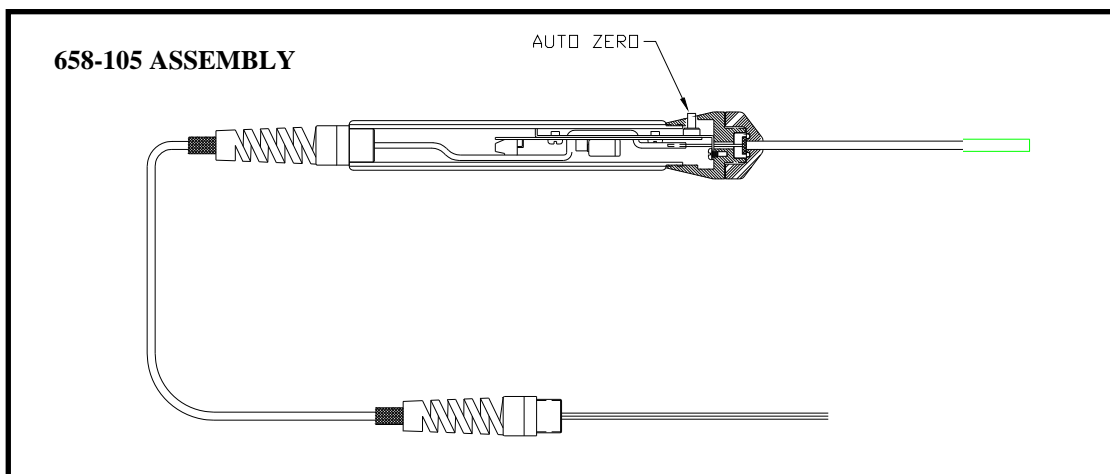

**SECTION 3.0 - Portable Helium Leak Detector Unit Specifications.**

**3.1 PERFORMANCE**

- Sensitivity:** Smallest detectable Helium leak rate  $5.0 \times 10^{-8}$  Atm-cc Helium (Atmospheric sniffer mode).
- Response Time:** Approximately 0.5 second using the fast response Hyper-Probe system.
- Leak Rate Range:**  $10^{-3}$  to  $10^{-8}$  Atm-cc/sec direct reading of Helium leak rate.
- Start-Up Time:** Less than 3 minutes.

**3.2 SPECTROMETER TUBE**

Miniaturized 90-deg deflection, fixed magnet design. All stainless steel construction, and a NW-40 flange for high vacuum connection. Utilizes two (2) non-burnout thoria coated iridium filaments.

**3.3 VACUUM SYSTEM**

- Fore-pump:** Diaphragm pump.
- High Vacuum Pump:** 30 liter/second air cooled Turbo-molecular pump.
- Inlet System:** Inter-stage design incorporating integral mass separator high flow atmospheric inlet. Standard sniffer probe hose length 10'. Optional hose available in various lengths.
- Pressure Measurement:** Selectable pressure display in either Torr or kPa

**3.4 ELECTRICAL**

- Console:** Microprocessor-based electronics, incorporating 40 character alphanumeric prompting display. Fully automatic operation including start-up, shutdown, leak rate ranging, zero control, and diagnostics including runtime, and operating parameters.
- Optional Remote Operation Box:** Contains 40 segment leak rate indicator and operator function controls. A 15' coiled cord is supplied. Longer lengths available upon request.

**3.5 POWER REQUIREMENTS**

Power Requirements: 115 volts, 60 hertz, 3.15 amps or 220VAC, 50 hertz, 3.15 amps

Fuse Listing refer to Main Electrical Schematic 936-163:

<b>SIZE/ TYPE</b>	<b>RATING</b>	<b>LOCATION</b>	<b>PURPOSE</b>
5 x 20 mm Normal	10 AMP	<b>F1</b> CPU	Fore-pump
5 x 20 mm Normal	1 AMP	<b>F2</b> CPU BOARD	Valve control
5 x 20 mm Time Delay	3.15 Amp	<b>FU 1</b> Back Panel	Main Power
5 x 20 mm Time delay	500 ma	<b>FU3</b> Din Mounted	Fan Assembly

**SECTION 4.0 - INSTALLATION AND OPERATION**

**4.1 UNCRATING**

Carefully remove the MD-490S PORTABLE LEAK DETECTORS from its shipping container being certain that the unit is not tipped on its side or turned upside down. The MD-490S leak test package should contain the following items: MD-490S Portable Helium Leak Test Unit with internal NIST traceable gas leak and Accessory Kit.

**VIC PART NUMBER: P/N 966-490 Universal Voltage Model**  
**P/N 966-492 CE Compliant Model**

Standard 10 ft Sniffer Probe. (Attached to unit).

**VIC PART NUMBER: P/N 658-109**

or

**Optional Vibra Leak Probe P/N 658-105**

Calibrated Leak Cylinder. (Internal to unit)

**VIC PART NUMBER: 752-150**

**Custom probes Assemblies and additional lengths available.**

**P/N 919-490 Accessory Kit Includes:**

Power Cable

Operational/Maintenance and Installation Manual

Certificate of Calibration for the Gas Leak Standard

2x Spare Filaments

6 sniffer probe tips

**NOTE:**

**RECOMMEND SAVING THE ORIGINAL SHIPPING CARTON, SO THAT IN THE EVENT THE UNIT IS SENT BACK FOR MAINTENANCE IT CAN BE PACKAGED PROPERLY.**

**4.2 SYSTEM START-UP**

**4.2.1** Insert the power cord into the back of unit, and plug into a 115 volt, 60 Hz, or 220 VAC 50 hertz 3.15 amp supply outlet. Turn on the main power switch located on the back of the unit. The alphanumeric (AN) display will prompt the user: POWER ON PRESS "START UP".

**4.2.2** If the AC power is interrupted when the unit is ready, the unit will automatically enter the start up sequence when the AC power is reapplied. Pressing the "Shut down" key, the unit will enable the shut down sequence disabling the automatic start up.

**4.3 SENSITIVITY CHECK/SYSTEM TUNING**

**4.3.1** The MD-490S is equipped with non-volatile memory. The memory is designed to store all SPECTROMETER TUBE operating parameters when power has been disconnected. To check sensitivity sniff the calibrated leak. The display should indicate the value of the leak.

**4.4 COMMENTS ON LEAK LOCATION**

**4.4.1** The direct probing of leaks to atmosphere technique is used to detect leaks in objects, which have been back-filled and pressurized with Helium tracer gas.

**4.4.2** The operator holds the sniffer probe perpendicular to the test object. In operation, as the probe tip is drawn over the exterior of the test object, it samples the atmosphere adjacent to the test object surface. Helium escaping from a leak, will be drawn into the probe tip and pass into the LEAK DETECTOR through the connecting tubing where it becomes visually evident on the leak rate meter.

**4.4.3** When probing products for general leakage location, always start leak probing from the lowest point on the product and proceed systematically to the highest point. This will prevent an unusual reading if a large leak is present at the lowest point and rises up. Probe at a rate of (1) one inch per second.

**Example:** Suppose the leakage area is a welded seam running around a vertical pipe. Holding the probe perpendicular to the surface of the pipe and moving slowly around the pipe weld will effectively locate the leakage point. When a leakage point is discovered, the area of leakage will be indicated by the largest rise in the leak rate meter.

**SECTION 5.0 – SHUTDOWN PROCEDURE**

**5.1 TEMPORARY/OVERNIGHT SHUT-DOWN (STAND BY MODE)**

**5.1.1** The MD-490S is equipped with a standby mode of operation. This mode is primarily designed to be used when the LEAK DETECTOR is not utilized for extended periods of time. To place the unit into this mode, press the 'STBY' key. Pressing the "Start up" will return the system to the operational start-up routine. See page #13 for “STBY” key details.

**5.2 COMPLETE SHUT DOWN OF SYSTEM**

**5.2.1** Press the 'shut down' key. The system will automatically go into a shutdown routine. The routine will consist of de-energizing all system valves and turning off the SPECTROMETER TUBE filaments.

**5.2.2** After approximately 5 minutes or when the turbo speed has been reduced below 10%, the prompt "POWER ON PRESS START UP" will be displayed. Turn off power at the rear of the LEAK DETECTOR. The MD-490S can now be stored or transported.

**NOTE:**

**DO NOT MOVE THE UNIT UNTIL THE TURBO HAS DROPPED BELOW 10% OF OPERATING SPEED TO AVOID TURBO BEARING DAMAGE.**

SECTION 6.0 – GENERAL MAINTENANCE

6.1 MAINTENANCE SCHEDULE

Sensitivity Check:	4 times per shift
Calibration:	Once per shift (every 8 hours)
Probe filter replacement:	once per day
Probe SS Metal filter cleaning or replacement:	monthly
Change filaments: (Spectrometer tube overhaul)	6,000 hours of operation or annually
Change oil wick assembly in turbo pump:	Annually (or 6000hrs)
Leak standard re calibration:	Annually or as indicated by the fall-off date on the leak std.
Complete inlet manifold overhaul:	6,000 hours of operation or annually.
Diaphragm pump overhaul:	Annually every 6,000 hours

**NOTE:**

**This is a suggested maintenance schedule, in order to minimize downtime and reduce operating costs the frequency of this schedule should be modified to reflect the cleanliness of the testing environment.**

6.2 INDICATIONS OF A CONTAMINATED VACUUM SYSTEM

“Internal Background” is an indication that the system may be leaking. To determine if a high Internal Background is present, do the following:

- 6.2.1 Press the "stop" key then turn the filaments off.
- 6.2.2 Perform an Auto zero function and then turn the filaments on.
- 6.2.3 An internal reading of greater than  $4 \times 10^{-5}$  indicates a high background with the “Stop” key activated. The system may have developed an atmospheric leak into the vacuum system.

**6.2.4** In the Non Sniffing Mode, spray the inlet manifold and associated plumbing with Helium to check for leaks.

### **6.3 General Remarks on Cleaning Procedures**

#### **6.3.1 Vacuum System**

In the event the vacuum system and/or SPECTROMETER TUBE becomes contaminated by high vapor pressure materials not easily removed by pumping and mild baking, it is necessary to disassemble and clean all component parts affected.

Many organizations have established cleaning procedures for vacuum apparatus such as electron tube parts, test chambers, etc. These methods will normally be appropriate for cleaning the mass spectrometer and system. Where cleaning procedures have not been established, the following remarks should prove useful to personnel not acquainted with the problems involved.

The specific processes used in cleaning will vary according to the material to be cleaned, nature of contaminant, facilities available and the degree of cleanliness desired. In general, the materials to be cleaned will vary from stainless tubing to O-rings. Internal surfaces that can be reached with clean cloth swabs should be physically swabbed out, using a minimum of degreasing solvent on the swab. Internal portions of the system that cannot be reached must be flushed with enough solvent to allow all surfaces to be wet, and as much physical action employed (shaking and sloshing) as practical. See section 6.3.3 for solvent types.

#### **6.3.2 Gaskets**

Synthetic rubber O-Rings (usually Buna N), are susceptible to absorbing large quantities of the solvents used in cleaning. The subsequent evaporation of these solvents when a system is evacuated must be avoided, therefore, O-Rings and gaskets should be removed from the flange grooves and treated as a separate cleaning problem. O-Rings and gaskets are either replaced at the time of reassemble (and this is recommended), or carefully wiped clean with a lint-free material and inspected for surface damage of any kind before they are used again. New O-Rings should be treated in the same manner as used ones.

Never remove O-Rings with a metal tool, as this will invariably scratch the O-Ring groove, causing a potential, if not actual, leak. Use plastic (e.g., corner of a plastic badge, etc.) or wood (e.g., toothpick), and remove O-Ring by inserting tool between outside of O-Ring groove and sliding around O-Ring. This will cause the O-Ring to "pop-up" (O-Ring may have to be held on opposite side to prevent turning in groove), and generally, gives better results than trying to pry the O-Ring from the groove.



### 6.3.3 Solvents

The solvents referred to are 99% isopropyl alcohol, trichloroethylene, acetone, or methanol alcohol. Trichloroethylene is used where deposits of grease and oil are to be removed. Acetone is preferred over trichloroethylene although precautions must be taken in either case. The inhalation of these vapors must be avoided, particularly in the case of trichloroethylene, and the flammable nature of the solvent presents an added hazard in the case of acetone.

Other cleaning agents such as soaps, alkali cleansers and synthetic detergents may be used as first-step cleaners provided complete facilities for thorough rinsing with hot distilled water are available.

### 6.3.4 Fore-pump

Before dismantling, allow the pump to cool down. Only dismantle the pump as far as it is necessary to effect repairs. See section 6.6.4 for maintenance procedure of the diaphragm pump.

## 6.4 MAINTENANCE OF THE VACUUM SYSTEM

A foremost basic requirement of the MD-490 series Mass Spectrometer operation is system cleanliness. The internal surface of the entire vacuum system should be maintained physically clean (lint, dust) and chemically clean (oils, solvents). Therefore, when repairing or maintaining components of the vacuum system, the utmost care should be exercised to prevent the entry of contaminating substances (oils, grease, lint, dirt, etc.) into the vacuum system. Washable parts generally may be cleansed in a suitable chlorinated solvent. Parts should be given a final rinse in clean solvent, and heat dried.

## 6.5 MASS SPECTROMETER TUBE

### 6.5.1 Source Removal/Installation for Filament Plate Replacement

**Required tools:**

- 3/16" Nut Driver
- 7/64" Hex Key Wrench
- 1/8" Blade Screwdriver

**NOTE:**

**SOURCE ASSEMBLY MAY BE RETURNED TO THE FACTORY FOR COMPLETE CLEANING AND FILAMENT REPLACEMENT P/N 952-108.**

- a) When the message "POWER ON PRESS START UP" appears, place the power switch, located on the back panel, to the OFF position. The power light will cease to illuminate.
- b) Remove the power cord connector from the back panel.

- c) Remove cover as previously described.
- d) Remove the electrical octal connectors from the source and collector assemblies.
- e) Unscrew the wing nut on the NW-40 quick disconnect clamp mating the SPECTROMETER TUBE to the Turbo pump, and be certain to hold SPECTROMETER TUBE firmly to avoid dropping.
- f) Place the SPECTROMETER TUBE in a clean area for repair. Place the NW-40 clamp and seal in a clean place.
- g) Remove the three 7/64 hex socket screws securing the source assembly to the SPECTROMETER TUBE body. The source is now free and may be removed by carefully pulling straight out of the body.
- h) Make sure the source is in a clean work area where it can be disassembled without the possibility of contamination from dirt or oils.
- i) Remove sealing O-Ring from source flange.
- j) The source contains a pair of thoria-coated iridium filaments. Each filament is mounted on a disposable Stainless steel plate. To remove the filament plate, first remove the screw, which secures the filaments electrical connection. Then, using a 3/16" nut driver, carefully remove the 3/16" nut located near the top of the filament plate. Once this has been performed, grasping the wire pigtail then lifts the plate straight out.

**NOTE:**

**RECOMMEND THAT BOTH FILAMENTS BE REPLACED AT THE SAME TIME. THIS WILL ENSURE THAT A SPARE NEW FILAMENT IS AVAILABLE IF NEEDED P/N 919-128.**

- k) At this time, the source must be properly cleaned before the new filaments are installed. Cleaning should be accomplished by first bead-blasting each part with a FINE, DRY glass blast at a low air pressure not exceeding 35 PSI. Then followed by blowing clean dry air over the source assembly, to remove any foreign particles left over from the sand blasting procedure.
- l) Install the new filament plates following the reverse order of procedure 7.1.10. Make certain all screws and nuts are securely tightened.
- m) Lightly lubricate the sealing O-Ring with high vacuum grease (The oring should appear shinny ). Before placing O-Ring in the groove, make certain that O-Ring groove is clean. Install O-Ring.

**NOTE:**

**IT IS RECOMMENDED THAT A NEW O-RING BE USED, CONSIDERING THE SENSITIVE NATURE OF THE MASS SPECTROMETER TUBE. SEE GENERAL PROCEDURES FOR CLEANING AND LUBRICATING ELASTOMER HIGH VACUUM SEALS.**

- n) Clean mating flange on SPECTROMETER TUBE and insert source into tube body. The proper orientation is to have the connector key way on the source at the 2 o'clock location, when holding the SPECTROMETER TUBE assembly with the vacuum manifold connection on the right side.
- o) Insert the three 7/64" x 1/2" long hex socket screws securing the source assembly to the SPECTROMETER TUBE body and tighten.

**NOTE:**

**AFTER SOURCE IS SECURED IN THE SPECTROMETER TUBE, ONE FILAMENT PLATE SHOULD BE FOUND VIEWED THROUGH THE VACUUM MANIFOLD CONNECTION.**

- p) Before installing SPECTROMETER TUBE, clean and lightly lubricate the NW-40 seal ring with high vacuum lubricant.
- q) Re-connect the flange to the vacuum manifold connection using NW-40 clamp. Tighten by hand only, do not use tools.
- r) Re-connect the octal electrical connections to source and collector assemblies.
- s) Tilt the back panel up to its closed position. Place the cover back on and verify that the locating screws align with their mating receptacles. Tighten the six screws.
- t) Perform "Start-Up" operating procedures to return the unit back into its operating conditions.

**6.5.2 Collector Removal/Installation**

- a) Perform complete Shut Down of System.
- b) When the message "POWER ON PRESS START UP" appears, place the power switch, located on the back panel, to the OFF position. The power light will cease to illuminate.
- c) Remove the power cord connector from the back panel.
- d) Remove cover as previously described.
- e) Remove the electrical octal connectors from the source and collector assemblies.
- f) Unscrew the wing nut on the NW-40 quick disconnect clamp mating the SPECTROMETER TUBE to the Turbo pump, and be certain to hold SPECTROMETER TUBE firmly to avoid dropping.
- g) Place the SPECTROMETER TUBE in a clean area for repair. And place the NW-40 clamp and seal in a clean place for proceeding assembly.

- h)** Remove the three 7/64" hex socket screws securing the collector assembly to the SPECTROMETER TUBE body.
- i)** Remove collector assembly from SPECTROMETER TUBE body by carefully pulling straight out of tube.
- j)** Replacement of the collector amplifier or any other component may now be performed in a clean work area to avoid contamination from dirt or oils.

**NOTE:**

THERE ARE TWO PRECISION EPOXY HIGH VALUE RESISTORS ( $10^{11}$  OHMS) MOUNTED TO THE INTERNAL COLLECTOR BOARD ASSEMBLY. DO NOT TOUCH THE EPOXY PORTION OF THE RESISTOR OR SUBJECT IT TO ANY FORM OF CONTAMINATION. OILS FROM FINGERS DEPOSITED ON THE EPOXY PORTION OF THE RESISTOR WILL CREATE A LESS ELECTRICALLY RESISTIVE PATH THAN THE RESISTOR ITSELF. SHOULD SUCH A CONDITION EXIST, SEVERE ERRATIC RESULTS WOULD BE ENCOUNTERED. IF ANY DOUBT EXISTS AS TO THE CLEANLINESS OF THE RESISTORS CAREFULLY CLEAN THE EPOXY WITH A CLOTH AND A CLEANING AGENT SUCH AS ACETONE, OR ALCOHOL.

- k)** Remove sealing O-Ring from flange, clean, lightly lubricate with high vacuum grease and replace in O-Ring groove.

**NOTE:**

SEE GENERAL PROCEDURES FOR CLEANING AND LUBRICATING RUBBER HIGH VACUUM SEALS.

- l)** Clean mating flange on SPECTROMETER TUBE and insert collector into tube body.

**NOTE:**

PROPER CONNECTOR ORIENTATION IS TO HAVE THE KEY WAY ON THE COLLECTOR AT THE 5 O'CLOCK POSITION, WHILE HOLDING THE SPECTROMETER TUBE ASSEMBLY WITH THE NW-40 FLANGE FACING YOUR LEFT SIDE.

- m)** Insert the three 7/64" x 1/2" long hex socket screws securing the collector assembly to the SPECTROMETER TUBE body and tighten.
- n)** Before installing SPECTROMETER TUBE, clean and lightly lubricate the NW-40 seal ring with high vacuum grease.
- o)** Install seal ring and re-connect the spec tube flange to the turbo pump inlet using NW-40 clamp. Tighten clamp by hand only, do not use tools.
- p)** Reconnect the octal electrical connections to source and collector assemblies.

- q) Tilt the back panel up to its closed position. Place the cover back on and verify that the locating screws align with their mating receptacles. Tighten the Four screws.
- r) Perform "Start-Up" operating procedures to return the unit back into its operating conditions.

### 6.5.3 Magnet Removal/Installation:

- a) Perform complete Shut Down of System.
- b) When the message "POWER ON PRESS START UP" appears, place the power switch, located on the back panel, to the OFF position. The power light will cease to illuminate.
- c) Remove the power cord connector from the back panel.
- d) Remove cover as previously described.
- e) Remove the 10-32 stainless steel screw securing magnet assembly to SPECTROMETER TUBE.
- f) The magnet may now be removed by grasping firmly and pulling straight up out of the mounting area.
- g) When installing magnet, be certain south-pole (marked with an "S") is on the same side of the SPECTROMETER TUBE as the vacuum system connection. Failure to insure this orientation will result in an inoperative SPECTROMETER TUBE.
- h) Insure that magnet is firmly seated in the "V" shaped portion of the tube body and secure the magnet to the SPECTROMETER TUBE body using the 10-32 screw provided.

#### NOTE:

The magnet screw provided is made of either brass or stainless steel for non-magnetic properties. If lost or damaged, do not replace this screw with another which is magnetic.

- i) Tilt the back panel up to its closed position. Place the cover back on and verify that the locating screws align with their mating receptacles. Tighten the four (4) screws.
- j) Perform "Start-Up" operating procedures to return the unit back into its operating conditions.

### 6.5.4 Removal/Installation of Complete Spectrometer Tube

- a) Perform complete Shut Down of System.
- b) When the message "POWER ON PRESS START UP" appears, place the power switch, located on the back panel, to the OFF position. **Remove the power cord from the power entry receptacle.**

- c) Remove cover as previously described.
- d) Remove the electrical octal connectors from the source and collector assemblies.
- e) Unscrew the wing nut on the NW-40 quick disconnect clamp mating the SPECTROMETER TUBE to the turbo pump, and be certain to hold SPECTROMETER TUBE firmly to avoid dropping.
- f) Place the SPECTROMETER TUBE in a clean area for later repairs. Place the NW-40 clamp and seal in a clean place for proceeding assembly.
- g) Before installing SPECTROMETER TUBE, clean and lightly lubricate the NW-40 seal ring with high vacuum grease.
- h) Install seal ring and re-connect the spec tube flange to the turbo pump inlet using NW-40 clamp. Tighten clamp, by hand only do not use tools.
- i) Re-connect the octal electrical connections to source and collector assemblies.
- j) Tilt the back panel up to its closed position. Place the cover back on and verify that the locating screws align with their mating receptacles. Tighten the Four (4) screws.
- k) Perform "Start-Up" operating procedures to return the unit back into its operating conditions.

## 6.6 VACUUM SYSTEM MAINTENANCE

### 6.6.1 Turbo-molecular Pump Removal/Installation

#### Turbo Removal

- a) Perform complete Shut Down of System.
  - a) When the message "POWER ON PRESS START UP" appears, place the power switch, located on the back panel, to the OFF position. **Remove the power cord from the power entry receptacle.**
  - b) Remove cover as previously described.
  - c) Unscrew the wing nut on the NW-16 quick disconnect clamp mating the manifold to the turbo pump, place the wing nut, screw and clamp in a safe place for later reuse. Let the manifold hang over the side of the unit.
  - d) Remove the electrical octal connectors from the source and collector assemblies.

- e) Unscrew the wing nut on the NW-40 quick disconnect clamp mating the SPECTROMETER TUBE to the turbo pump, and be certain to hold SPECTROMETER TUBE firmly to avoid dropping
- f) Place the SPECTROMETER TUBE in a clean. Place the NW-40 clamp and seal in a clean area for proceeding assembly.
- g) Locate and remove the fitting that connects the turbo exhaust hose. The exhaust hose is connected between the turbo and diaphragm pump.
- h) Gently bend the turbo exhaust hose out of the way being careful not to crimp the hose.
- i) Locate, unlock, and remove turbo pump electrical connector.
- j) From underneath, remove the (4) #10-32 socket cap screws securing the turbo. Place screws and washers in safe area for proceeding assembly. Use supplied plugs to cover all ports on the turbo pump.
- k) Place original turbo vertically at the center of the workbench.

### **Turbo Installation**

**NOTE:**

**PRIOR TO SEAL RING INSTALLATIONS, CLEAN SEAL RINGS AND LIGHTLY LUBRICATE USING HIGH VACUUM GREASE.**

- a) Remove any plugs coving turbo ports. Position turbo over case bottom access hole. From underneath, attach turbo to base plate using the four (4) #10-32 socket head screws.
- b) Install fitting with hose to turbo pump exhaust port.
- b) Install electrical connector to integral turbo pump power supply.
- c) Attach manifold to turbo pump flange with NW-16 clamp and o-ring. Tighten clamp, finger tight only, DO NOT use any tools.
- d) Install NW-40 seal ring and attach SPECTROMETER TUBE onto turbo pump inlet flange using NW-40 clamp. Tighten clamp, finger tight only, DO NOT use any tools.
- e) Reconnect the octal electrical connections to source and collector assemblies.

- f) Tilt the back panel up to its closed position. Tighten the Four (4) screws.
- g) Perform "Start-Up" operating procedures to return the unit back into its operating conditions.

### 6.6.2 Turbo Pump Lubricant Reservoir Replacement

NOTE: THE REPLACEMENT OF THE WICK SHOULD BE PERFORMED ONCE A YEAR OR MORE FREQUENTLY WHEN LONG PERIODS OF USE WITH HIGH AMBIENT TEMPERATURES OR AIR THAT HAS A HIGH PARTICULATE COUNT. THE WICK IS PRE-LUBRICATED WITH OIL PRIOR TO SHIPMENT. IT SHOULD BE HANDLED WITH GLOVES.

- a) Perform complete Shut Down of System.
- b) When the message "POWER ON PRESS START UP" appears, place the power switch, located on the back panel, to the OFF position. **Remove the power cord from the power entry receptacle.**
- c) The oil wick is accessed through the bottom of the turbo. Carefully position the MD490 on its back cover or over a table edge to gain access to the turbo wick. If necessary, the turbo pump can be removed.
- d) Locate the locking cover on the under side of the turbo pump. Remove the locking cover with an adjustable pin key. Be careful with o-ring.
- e) Lever out the lubricant reservoir with the help of two screwdrivers.
- f) Use a lint free cloth to clean O-Ring, locking cover and turbo pump from dirt and debris.
- g) Insert new lubricant reservoir, which is already filled with lubricant (Part# 917-126).
- h) Screw in the locking cover with o-ring. The lubricant reservoir will adjust itself into the correct position with the locking cover in place.
- i) Position the MD490 into its normal operating position.
- j) Perform "Start-Up" operating procedure to return the unit back into its operating conditions.



### 6.6.3 Fore-pump Removal/Installation

#### Fore-pump Removal

- a) Perform complete Shut Down of System.
- b) Turn power switch off.
- c) Remove the power cord connector from the back panel.
- d) Remove cover as previously described.
- e) Remove inter-stage tube between fore-pump and turbo.
- f) Remove nut and washers on pump's feet. Place nut and washer in safe area for proceeding assembly.
- g) Unplug.
- h) Remove Pump.

#### Fore-pump Installation

- a) Do the reverse of Fore-pump removal.
- b) Tilt the back panel up to its closed position. Place the cover back on and verify that the locating screws align with their mating receptacles. Tighten the Four (4) screws.
- c) Perform "Start-Up" operating procedures to return the unit back into its operating conditions.

### 6.6.4 Fore-pump Membrane Head change.

- a) Refer to manufacturers product manual for replacements.  
Diaphragm rebuild kit VIC P/N 919-193

Page Left Blank Intentionally

### 6.6.5 Vacuum Manifold Removal Procedure

- a) Perform complete Shut Down of System.
- b) When the message "POWER ON PRESS START UP" appears, place the power switch, located on the back panel, to the OFF position. **Remove the power cord from the power entry receptacle.**
- c) Remove cover as previously described.
- d) Tilt electronic support bracket back to open up work-space.
- e) Remove the red hose from the PROBE VALVE.
- f) Remove the BALLAST BOARD CONNECTOR from the BALLAST BOARD.
- g) Remove wing-nut on the NW-16 clamp of the TURBO PUMP PORT.
- h) Remove the NW-16 clamp off of the TURBO PUMP PORT.
- i) Remove inter-stage tube connector at fore-pump.
- j) The MANIFOLD ASSEMBLY can now be removed.

#### NOTE:

A VACUUM SEAL WILL BE BREACHED WHEN DISCONNECTING THE INTER-STAGE AND TURBO PUMP PORT CONNECTIONS.

### 6.6.6 Orifice Replacement

- a) Unscrew the two #4-40 captive screws securing the ballast board assembly to the manifold assembly. Carefully remove the ballast board and the WASHER SEAL (VIC PART NO. 489-798-0039) and place it in a clean area for the proceeding assembly.
- b) Remove the two # 7/64 socket head screws securing the orifice manifold to the transport manifold.
- c) Carefully separate the two manifold sections.
- d) Remove the two (2) O-Rings (VIC PART NO. 492-092-2010) and the orifice.
- e) Wipe the manifold surfaces with a clean lint free cloth and alcohol.

- f) Reinstall the two (2) O-Rings and the orifice by compressing the ORIFICE between the two (2) O-Rings and placing this assembly into the MASS SEPARATOR COUNTER-BORE.
- g) Insert the two # 7/64 x 1 1/4" long screws into the orifice section of the manifold. Place the orifice section over the MASS SEPARATOR section, aligning the screws. Verify that the manifold mounting flange and the transport tubing are both facing the same direction.
- h) Reinstall the ballast board assembly by first placing the WASHER SEAL into the counter-bore and tightening equally both #4-40 captive screws.

#### **6.6.7 Manifold Disassembly Procedures**

**NOTE: PLEASE REFER TO THE MANIFOLD REMOVAL PROCEDURE IN SECTION 6.6.5 BEFORE PROCEEDING WITH THIS SECTION.**

- a) Unscrew the two #4-40 captive screws securing the ballast board assembly to the manifold assembly. Carefully remove the ballast board and the WASHER SEAL (VIC PART NO. 489-798-0039) and place it in a clean area for the proceeding assembly.
- b) Remove the two #7/64 socket head screws securing the orifice manifold to the transport manifold.
- c) Carefully separate the two manifold sections.
- d) Remove the two 2-010 O-Rings (VIC PART NO. 492-092-2010) and the orifice.
- e) Remove the two #7/64 x 1-1/4" socket head screws securing the orifice manifold to the manifold mounting flange. Also, remove the O-Ring #2-006.
- f) Remove the four screws securing the Flow Control Valve Assembly to the transport manifold block.
- g) Using a 5/16" open-end wrench, carefully unscrew the sniffer probe fitting from probe valve.
- h) Pry off, using a flat blade screwdriver, the retaining clip is used to secure the probe valve solenoid. The solenoid can now be removed.
- i) Remove the four #4-40 x 1/4" flat head Phillips screws securing the solenoid valve body to the transport manifold block.
- j) Carefully lift off the solenoid valve body as not to drop the core assembly and the spring that is contained within.
- k) Remove the brass barbed fitting and black tygon tubing that connects the manifold to the diaphragm pump.

**6.6.8 Flow Control Valve Assembly Replacement (FCVA) and Adjustment:**

- a) Prior to installing the new FCVA apply a small quantity of vacuum grease to the two o-rings.
- b) Install the FCVA into the manifold assembly using the four #4-40 x 1 1/4" pan head Phillips head screws. Do not over tighten the screws.
- c) Start the MD 490-s as described in section 4.0 subsection 4.2

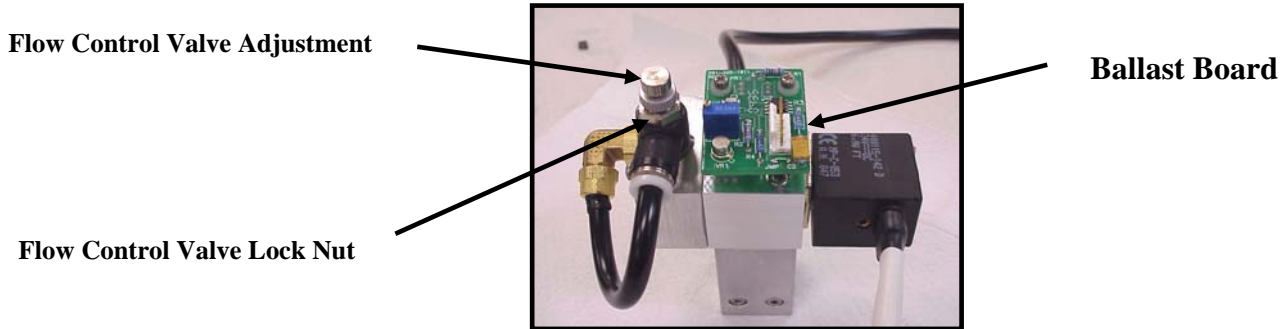

This assembly was factory set for a 10' sniffer probe. If there is a need to fine tune the flow control valve or re-adjust the ballast pressure for an extended length probe, proceed with the following instructions.

**To adjust the ballast pressure**

**Note:** This adjustment should only be performed while the unit is in test mode and the diagnostic screen for Ballast Pressure / Setpoint is being displayed.

To display the Ballast Pressure Press the “Dia” key six times. The unit must be in “test” mode during any adjustments. The ballast pressure should be set between 185 to 205 Torr. This adjustment is accomplished by loosening the flow control valve lock nut, adjusting the flow control valve between 185 to 205 Torr, then re-tightening the flow control valve lock nut. Note that the valve adjustment is very sensitive and the response to an adjustment takes a few seconds before the Torr reading stabilizes. Do not rush this procedure. Once the ballast pressure is set, the “Setpoint” (probe blocked pressure setpoint) reading should be adjusted to approximately 50 Torr below the ballast pressure setting. Example if the ballast pressure is 200 Torr, the setpoint should be at approximately 150 Torr.

**To adjust the Probe Blocked Pressure Setpoint:**

Press the “EXIT” key twice to exit the diagnostic screen. Press the “MENU” key twice to get to the “MENU #2 SETUP” screen, then press the “ENTER” key. This will display the “Probe Blocked Press. Setpoint” adjustment screen. This setting is adjusted by pressing the up or down arrow. Adjust this to approximately 50 Torr below the ballast pressure setpoint. Once this has been achieved press the “Exit “ key twice for the “In Test” screen.

**6.6.9 Ballast Pressure Transducer Replacement and Adjustment:**

- a) The system should be fully turned off as indicated in section 5.0 sub section 5.2
- b) Remove the ballast transducer as indicated in section 6.6.7 appendix A.
- c) Install the new ballast board
- d) Turn on the unit main power, **DO NOT START THE UNIT**
- e) Press the DIAG key until the ballast pressure is displayed.
- f) Adjust the potentiometer slowly until the ballast pressure displays 760 torr or XXX kpa
- g) Wait 1 minute to allow the transducer to stabilize. Readjust until the ballast pressure maintains 760 torr or XXX kpa

**TURBO AND INLET MANIFOLD ASSEMBLY**

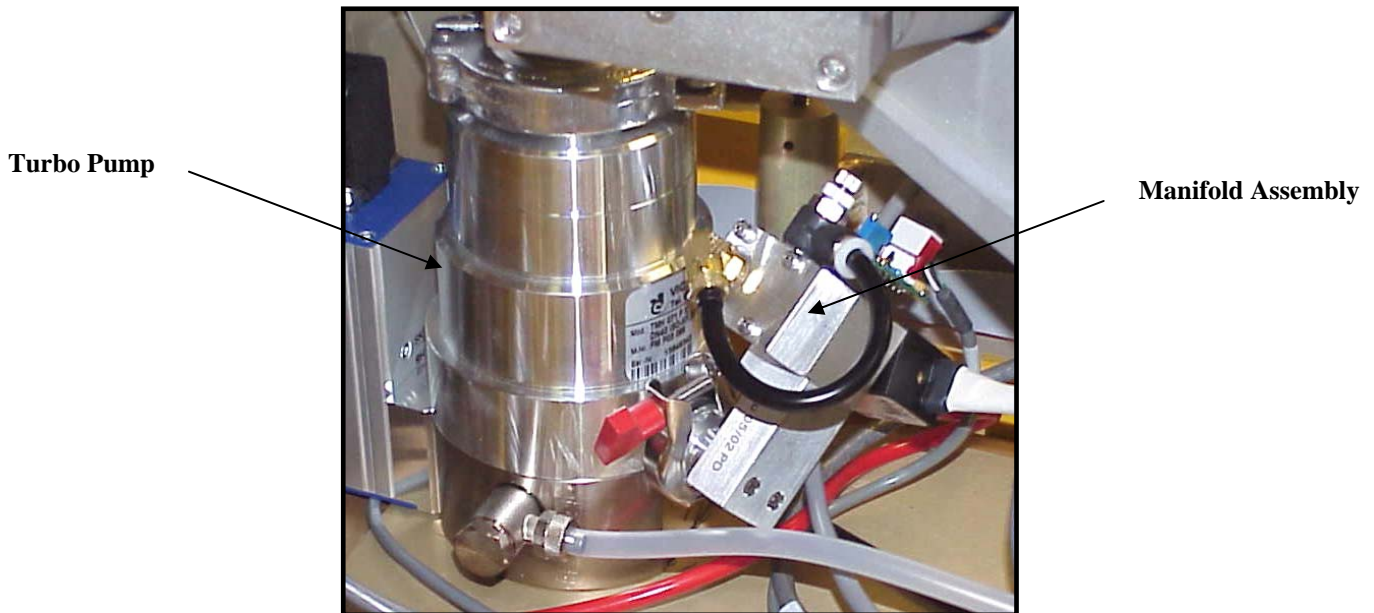

## 6.7 ELECTRONIC ASSEMBLIES

### 6.7.1 Main Power Supply Removal/Installation

#### Power Supply Removal

- a) Perform complete Shut Down of System. Refer to SECTION 5.0, sub-section 5.2.
- b) When the message "POWER ON PRESS START UP" appears, place the power switch, located on the back panel, to the OFF position. **Remove the power cord from the power entry receptacle.**
- c) Remove cover as previously described.
- d) Push back vertical support.
- e) Remove Power Supply cables. Note on right side cable the red wire connects to the bottom terminal, and the black wire connects to the top terminal.
- f) From the outside of the unit, remove the four screws securing the power supply. Place screws and washers in a safe place for proceeding assembly.
- g) Slide power supply up to clear rear panel.
- h) Do the reverse of the power supply removal.
- i) Tilt the back panel up to its closed position. Place the cover back on and verify that the locating screws align with their mating receptacles. Tighten the four screws.
- j) Perform "Start-Up" operating procedures to return the unit back into its operating conditions. See section 4.0 sub section 4.2

## 6.7.2 PC Board Removal/Installation

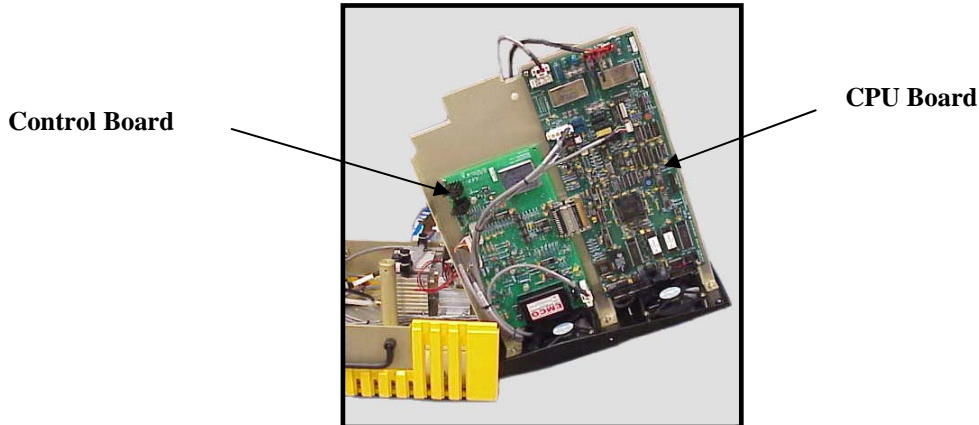

### PC Board Removal

- a) Perform complete Shut Down of System.
- b) When the message "POWER ON PRESS START UP" appears, place the power switch, located on the back panel, to the OFF position. **Remove the power cord from the power entry receptacle.**
- c) Remove cover as previously described.

#### NOTE:

IT IS NECESSARY TO WAIT ONE MINUTE AFTER PLACING THE POWER SWITCH TO THE OFF POSITION TO BEGIN REMOVING PC BOARDS. THERE ARE HIGH VOLTAGE CAPACITORS PRESENT WHICH NEED TO DISCHARGE IN THIS TIME AND COULD HAVE A POTENTIALLY HIGH VOLTAGE PRESENT BEFORE ONE MINUTE DURATION.

- d) Disconnect all connectors from PC boards and place out of the way.
- e) Locate and remove (8) screws and washers and place in a safe location.
- f) Gently lift both PC boards from unit. Place boards on the static protected work bench..

### PC Board Installation

- a) Do the reverse of the PC board removal.
- b) Tilt the back panel up to its closed position. Place the cover back on and verify that the locating screws align with their mating receptacles. Tighten the four screws.
- c) Perform "Start-Up" operating procedures to return the unit back into its operating conditions.



**ELECTROSTATIC DISCHARGE CAUTION**

ELECTROSTATIC DISCHARGE CAN DAMAGE ELECTROSTATIC SENSITIVE ELECTRONIC COMPONENTS. THEREFORE IT IS NECESSARY TO TAKE SPECIAL PRECAUTIONS WHEN HANDLING THESE COMPONENTS AS FOLLOWS:

- √ BEFORE HANDLING ANY COMPONENTS OR TOUCHING ANYTHING INSIDE THE SYSTEM, WEAR A PROPERLY CONNECTED GROUNDING STRAP. IF ONE IS NOT AVAILABLE, DISCHARGE YOUR BODY'S STATIC CHARGE BY TOUCHING PART OF THE SYSTEMS METAL CHASSIS.
- √ DO NOT REMOVE ANY PARTS FROM THEIR ANTI-STATIC BAGS UNTIL YOU ARE GROUNDED AND READY TO INSTALL THEM.
- √ DO NOT LAY ANY PARTS ON ANTI-STATIC BAGS, THEY ARE ONLY ANTIS-STATIC ON THE INSIDE.
- √ HANDLE ANY PARTS BY THEIR EDGES AND METAL MOUNTING BRACKETS. AVOID TOUCHING BOARD COMPONENTS OR EDGE CONNECTORS.
- √ DO NOT SLIDE PARTS ACROSS SURFACES, THIS INDUCES STATIC CHARGE BUILDUP.
- √ AVOID PLASTIC, VINYL, STYROFOAM AND FABRICS IN THE VICINITY.

SECTION 7.0 – SYSTEM SOFTWARE

7.1 KEYPAD MENU AND DIAGNOSTIC FUNCTIONS

The MD-490S is equipped with a software system menu and diagnostic function accessible from the front panel keypad. This menu system allows MD-490S configuration (setup) and operation monitoring.

There are three (3) primary menu structures; MENU, DIAG and AUDIO. The MENU, DIAG and AUDIO menu displays are started using the MENU, DIAG and VOL keys, respectively. To advance through the displays and make selections the ↑, ↓, ENTER and EXIT keys are used. Generally, these keys are used as follows:

- ↑ / ↓ To increment/ decrement system values. No special screen prompts are given except an occasional blinking value.
- ENTER to toggle a function mode from "ON" to "OFF". Also, used to enter a sub menu, select system units and reset counter values.
- EXIT to leave a particular menu.

The MENU displays are composed of four (4) sub menus; MENU #1 - SENSITIVITY, MENU #2 - SYSTEM SETUP, MENU #3 - OPTIONS, MENU #4 - RESET HOURS. From these displays the ENTER and EXIT keys are used to access the specific parameter displays. When in these displays the MENU key is used to view the desired display.

**MENU #1** is used to adjust the electron EMISSION, system GAIN and perform a MANUAL TUNE.

**MENU #2** is used to configure the system using ten (10) standard setup sub-menus.

**MENU #3** is used to view the system options and the unit program revision.

**MENU #4** is used to reset logged hours for system components operation.

The following diagrams illustrate the actual menu structures.

**7.2 MENU #1 FUNCTIONAL DIAGRAM**

MENU KEY  
⇓

MENU #1 SENSITIVITY  
  
ENTER> CHANGE

ENTER KEY  
EXIT KEY ←

EMISSION LEAK RATE  
  
X.XX mA

MENU KEY  
⇓

MANUAL TUNE/LEAK RATE  
  
XXX VOLTS

MENU KEY  
⇓

GAIN - A XXX LEAK RATE

**NOTE: USE UP/DOWN ARROW KEYS ON FRONT MEMBRANE PANEL TO ADJUST. KEY MUST BE IN UNLOCKED POSITION.**

7.3 MENU #2 FUNCTIONAL DIAGRAM

MENU KEY  
⇓

MENU #2 SYSTEM SETUP  
ENTER> SELECT

ENTER KEY ⇒  
EXIT KEY ⇐

PROBE BLOCKED PRESS.  
SETPOINT XXX Torr or kpa

760 torr = 101.325 kPa

MENU KEY  
⇓

SETPOINTS ON  
ENTER>OFF

MENU KEY  
⇓

SP#1 X.XE-XX cc/sec  
SP#2 X.XE-XX cc/sec

MENU KEY  
⇓

CALIBRATED LEAK  
X.XE-XX cc/sec

MENU KEY

⇓

LEAK RATE DISP. OFF  
ENTER> TURN ON

7.3 MENU #2 FUNCTIONAL DIAGRAM continued

Note this menu selection is displayed only if the com option is factory enabled.

MENU KEY

AUDIO MODE -1 ON  
ENTER>SELECT MODE -2

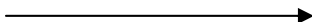

SELECT UNITS GM/YR  
Pa m3s/ CC/SEC OZ/YR

MENU KEY



RECALIBRATION WATCHDOG  
TIMER ALARM

MENU KEY



TURBO SPEED  
750 Hz +/- 5

MENU KEY



SELECT PRESSURE UNITS  
Torr or kPa

M  
MENU KEY



ZERO SUPPRESS ON  
ENTER> TURNOFF

TO FIRST MENU OPTIONS



7.4 MENU #3 FUNCTIONAL DIAGRAM

MENU KEY  
⇓

MENU #3 OPTIONS  
ENTER> SELECT

ENTER KEY ⇒  
EXIT KEY ⇐

COMMUNICATION OPTION  
DISABLED

**Options can only be ENABLED by installing a Factory programmed EPROM. When ordering options for existing units please specify the S/N, program version and whether any options are currently enabled.**

MENU KEY  
⇓

LEAK RATE ANALOG OUT  
DISABLED

MENU KEY  
⇓

REMOTE I/O  
DISABLED

MENU KEY  
⇓

PROGRAM VERSION  
490S.XXX

7.5 MENU #4 FUNCTIONAL DIAGRAM

MENU KEY



MENU #4 RESET HOURS  
ENTER> SELECT

ENTER KEY =>  
EXIT KEY <=

TURBO PUMP XXXXXXhrs  
ENTER>RESET HOURS

MENU KEY



FILAMENT-A XXXXXXhrs  
ENTER>RESET HOURS

MENU KEY



FILAMENT-B XXXXXXhrs  
ENTER>RESET HOURS

MENU KEY



FOREPUMP XXXXXXhrs  
ENTER>RESET HOURS

7.6 DIAG FUNCTIONAL DIAGRAM

DIAG KEY



TURBO PUMP	XXXhrs
FORE-PUMP	XXXhrs

DIAG KEY



A FILAMENT	XXXXXXhrs
B FILAMENT	XXXXXXhrs

DIAG KEY



XXX	XXX	XXX	XXX
TUNE	STF	A	C

DIAG KEY



EMISSION	X.XX mAMPS
FIL. CURR.	X.X AMPS

DIAG KEY



GAIN (FIL A)	XXX
GAIN (FIL B)	XXX



7.6 DIAG FUNCTIONAL DIAGRAM continued

DIAG KEY



BALLAST PR. XXX Torr/Kpa  
SETPOINT XXX or/Kpa

DIAG KEY



COLLECT XXX.XX VLTS  
S-PLATE XXX VLTS

DIAG KEY



TURBO SPEED XX Hz  
BOARD TEMP. XX F

**VOL FUNCTION**

VOL KEY



VOLUME LEVEL XXX %

VOL KEY



AUDIO OFF  
ENTER>ON

**SECTION 8.0\_TROUBLE SHOOTING**

**8.1 Alphanumeric Display**

The display is a user-friendly alphanumeric display (AN) that prompts the users through all system operations. Display format is 2 x 20 characters. The following prompts will appear on the bottom half of the display.

**8.2 ERROR MESSAGES**

<b>FAULT</b>	<b>POSSIBLE CAUSE</b>	<b>SOLUTION</b>
COLLECTOR OR SATURATED	The collector voltage is less than full-scale of – 10vdc	<ol style="list-style-type: none"> <li>1. Check that the collector assembly connector is plugged in. If it is, replace the collector and retest.</li> <li>2.. Check that the CONTROL BOARD and connections are fully secured, replace the board and retest</li> <li>3. Check that the CPU BOARD electrical connections are fully secure, replace the board and retest.</li> </ol>
FIL CURRENT	The filament is ON and the filament current is less than 1 amp.	<ol style="list-style-type: none"> <li>1. Verify that source ass’y electrical connection is plugged in a both the source and control board</li> <li>2. Switch Filaments and retest, one of the filaments may have failed.</li> <li>3.. Replace filaments</li> <li>4. There may be a short in the source assembly, perform a continuity test between the Source plates.</li> <li>5. The Control board may have failed, replace the board</li> </ol>
A-PLATE VOLTAGE	Short in the source	<ol style="list-style-type: none"> <li>1. Check the A plate voltage with the source electrical connection attached and unplugged, if the voltage changes more than 5 vdc than there may be a short in the source, perform a continuity test between the Source plates.</li> <li>2. Switch Filaments and retest, one of the filaments may have failed.</li> <li>3. Replace filaments</li> <li>4. The Control board may have failed, replace the board and retest.</li> </ol>
STF VOLTAGE FAULT	Short in the source	<ol style="list-style-type: none"> <li>1. Check the STF plate voltage with the source electrical connection attached and unplugged, if the voltage changes more than 5 vdc than there may be a short in the source, perform a continuity test between the Source plates.</li> <li>2. Switch Filaments and retest, one of the filaments may have failed.</li> <li>3. Replace filaments</li> <li>4. The Control board may have failed replace the board and retest.</li> </ol>
TUNE VOLTAGE FAULT	Short in the source	<ol style="list-style-type: none"> <li>1. Check the TUNE plate voltage with the source electrical connection attached and unplugged, if the voltage changes more than 5 vdc than there may be a short in the source, perform a continuity test between the Source plates.</li> <li>2. Switch Filaments and retest, one of the filaments may have failed.</li> <li>3. Replace filaments</li> <li>4. The Control board may have failed replace the board and retest</li> </ol>
SPLATE VOLTAGE FAULT	Control Board Failure	<ol style="list-style-type: none"> <li>1. There is a short within the collector assembly, remove the collector and perform a continuity test between the plates.</li> <li>2. Inspect the collector harness connections at the control board J1 and the collector assembly.</li> <li>3. Replace the control board.</li> </ol>

**MANUAL- MD-490S PORTABLE HELIUM LEAK DETECTOR**

<b>FAULT</b>	<b>POSSIBLE CAUSE</b>	<b>SOLUTION</b>
C-PLATE FAULT	Short in the source	<ol style="list-style-type: none"> <li>1. Check the C plate voltage with the source electrical connection attached and unplugged, if the voltage changes more than 5 vdc than there may be a short in the source, perform a continuity test between the Source plates.</li> <li>2. Switch Filaments and retest, one of the filaments may have failed.</li> <li>3. Replace filaments</li> <li>4. The Control board may have failed, replace the board and retest.</li> </ol>
EMISSION FAULT	Short in source or blown filament	<ol style="list-style-type: none"> <li>1. Verify that source ass'y electrical connection is plugged in a both the source and control board</li> <li>2. Switch Filaments and retest, one of the filaments may have failed.</li> <li>3. Replace filaments</li> <li>4. There may be and short in the source assembly, perform a continuity test between the Source plates.</li> <li>5. The Control board may have failed, replace the board</li> </ol>
BALLAST TXDCER FAULT	Transducer is blown or unplugged	<ol style="list-style-type: none"> <li>1. Check that the transducer cable is attached at the ballast board and CPU board J4.</li> <li>2. Calibrate the transducer by venting the unit to ATM and adjusting the trim pot on the ballast board until the displayed pressure is at 760 torr or 101.325 kPa.</li> <li>3. Replace the transducer board and recalibrate.</li> </ol>
GAIN FAULT 49	System is over sensitive.	<ol style="list-style-type: none"> <li>1. Confirm that the correct value for the internal gas leak has been programmed.</li> <li>2. Check the ballast pressure in test, ballast pressure using a standard 10-ft probe is 190 torr or 25.33 kPa.. Adjustments to the flow can be made via the vacuum regulator. If the flow is not adjustable the Regulator may require replacement.</li> <li>3. Probe the gas leak and reduce the emission until the leak rate corresponds to value of the calibrator.</li> </ol>
GAIN FAULT 201	System is under sensitive	<ol style="list-style-type: none"> <li>1. Confirm that the correct value for the internal gas leak has been programmed.</li> <li>2. Check the ballast pressure in test, ballast pressure using a standard 10-ft probe is 190 torr or 25.33 kPa.. Adjustments to the flow can be made via the vacuum regulator. If the flow is adjustable the regulator may require replacement or the is a cog in the sniffer probe</li> <li>3. The aperture disk may be clogged and requires cleaning.</li> <li>4. Probe the gas leak and increase the emission until the leak rate corresponds to value of the calibrator.</li> </ol>
PROBE BLOCKED FAULT	Ballast pressure is below the probe blocked set point	<ol style="list-style-type: none"> <li>1. Check the ballast pressure set point, it should be 50 torr or 7 kPa below the current ballast pressure.</li> <li>2. The sniffer probe tubing or probe filters may be clogged and require replacement.</li> <li>3. The ballast pressure may require adjustment standard 10 ft probe should be at 190 torr or 25.33 kPa.</li> </ol>

**MANUAL- MD-490S PORTABLE HELIUM LEAK DETECTOR**

<b>FAULT</b>	<b>POSSIBLE CAUSE</b>	<b>SOLUTION</b>
PUMP-DOWN TIME-OUT FAULT	Turbo did not reach operating speed after three minutes	<ol style="list-style-type: none"> <li>1. The diaphragm fore pump required to back the turbo pump is off or seized. Measure the 24 VDC supplied to the pump.</li> <li>2. The turbo pump electrical connection is not secured at X2 or the RS 485 port. See the electrical schematic for details.</li> <li>3. The turbo has seized, remove the spectrometer tube to gain access to the turbo blades. The blades should move easily, if they are difficult to rotate the pump requires replacement</li> </ol>
No-Helium Sensitivity	Unit is not calibrated	<ol style="list-style-type: none"> <li>1. Place the unit in test mode and calibrate. If the unit is unable to calibrate a fault will be displayed. See GAIN FAULT.</li> <li>2. The sniffer probe tubing or probe filters may be clogged and require replacement.</li> <li>3. The ballast pressure may require adjustment standard 10 ft probe should be at 190 torr or 25.33 kPa</li> <li>4. The aperture disk may be clogged and requires cleaning.</li> <li>5. Probe the gas leak and increase the emission until the leak rate corresponds to value of the calibrator</li> <li>6. Check the magnet orientation, the stamped "S" should be on the vacuum inlet side of the spectrometer tube.</li> <li>7. Place the unit in testing mode and probe the gas leak. Manually adjust the TUNE voltage by increasing or decreasing the value until the maximum deflection is obtained on the leak rate meter.</li> </ol>
FORE-PUMP WILL-NOT START	No Power to the fore pump	<ol style="list-style-type: none"> <li>1. Check the pump power cord and ensure it is plugged in.</li> <li>2. Measure the 24 VDC supply for the pump at the CPU board J1 or TB1-4 and TB1-5.</li> <li>3. Check Fuse J1 on the CPU board for continuity.</li> <li>4. The pump may be seized and requires replacement</li> </ol>
SYSTEM WILL NOT POWER UP	Main power is disconnected	<ol style="list-style-type: none"> <li>1. Check that the main power of 110 or 220 VAC is being provided.</li> <li>2. Measure FU1 to ensure it has not blown.</li> <li>3. Remove the display cable from CPU board at J10 and at the display board at J3 and re connect.</li> </ol>
LEAK RATE IS UNSTABLE	High ambient helium levels in the testing area	<ol style="list-style-type: none"> <li>1. Remove the unit from the testing mode and confirm whether the leak rate is still unstable. If the leak rate is stable the background helium levels may be elevated due to large leak within the helium supply gas and should be repaired. If the leak rate is still unstable there may be an atmospheric leak in the 490-S vacuum system.</li> <li>2. The collector may have failed and requires repair or replacement</li> <li>3. There may be a short in the source assembly, measure the optic voltage with source connected and unplugged. The voltage should not change more than 5 VDC.</li> </ol>

**SECTION 9.0 – RECOMMENDED SPARE PARTS**

<b>PART #</b>	<b>DESCRIPTION</b>	<b>QTY.</b>	<b>UNIT</b>
651-150	MASS SPECTROMETER TUBE ASSY	1	EA
919-128	FILAMENT KIT 4/BOX	1	EA
353-691-1015	TURBO PUMP ASSEMBLY	1	EA
312-191-2067	DIAPHRAGM PUMP	1	EA
917-126	REPLACEMENT PUMP FLUID RESERVOIR FOR TURBO PUMP	1	EA
919-554	GASKET SET (ALL O-RINGS AND SEALS)	1	EA
752-150	CALIBRATED GAS LEAK ASSY	1	EA
011-213-1507	SNIFFER TUBING ( RED TUBING STD PROBE )	1	EA
741-117	FILTER ASSEMBLY SNIFFER (BOX OF 50)	1	EA
413-613-1003	SS FILTER, PROBE ASSEMBLY	1	EA
452-681-1032	MANIFOLD, MASS SEPARATOR	1	EA
452-691-1024	APERTURE, PINHOLE GROSS ORIFICE	1	EA
656-190	MEMBRANE ASSY CONTROL PANEL	1	EA
584-441	PC BOARD ASSEMBLY CPU DC	1	EA
584-444	PC BOARD ASSEMBLY CONTROL DC	1	EA
584-335	PC BOARD ASSEMBLY BALLAST	1	EA
584-330	PC BOARD DISPLAY	1	EA
583-336	PC BOARD ASSEMBLY, ALPHANUMERIC	1	EA
366-381-2245	KEY SWITCH	1	EA
658-105	VIBRATING SNIFFER PROBE ASSEMBLY	1	EA
658-109	SNIFFER PROBE ASSEMBLY STANDARD 10 FT	1	EA
952-225	490-S MAINTENANCE KIT	1	EA

**MANUAL- MD-490S PORTABLE HELIUM LEAK DETECTOR**

**SECTION 10.0 – BILL OF MATERIALS for major components**

Parent Item 966-490	Leak detector, Universal Voltage	
P/N	REF	DESCRIPTION
766-500	10	MD490S, Leak Detector Assy MD490S (UNIVERSIAL VOLTAGE)
658-109	20	SNIFFER PROBE, STANDARD MD490S
861-029	30	manual, MD490S
919-490	40	KIT, SPARES MD490S LEAK DETECTOR
570-009	50	Label, MD490S serial/ratings
570-010	60	Label, Fuse Identification CPU BOARD, MD490S/490M

Parent Item 766-500	MD490S, Leak Detector Assy MD490S (UNIVERSIAL VOLTAGE)	
P/N	REF	DESCRIPTION
766-612	1	ENCLOSURE ASSEMBLY MD490S
931-124	2	VACUUM ASSEMBLY MD-490S
936-163	3	Cable Package, MD490S-CE MD490S-CE
752-150	4	calibrator, mo-5 type, md-390s gas leak
464-091-1005	5	CALIBRATOR STRAP
426-091-0005	6	Lanyard, Panel Support 10"
488-091-0001	7	Handle W/BLACK EPOXY FINISH
78002005	8	BUMPER FOOT, BLACK RUBBER
362-381-0416	9	speaker, 4"
366-381-2245	10	Switch, Keylock
311-092-3625	11	Fan, Cabnet, 3610, 24v, wires
584-441	12	PC Board Assembly, CPU-DC
584-444	13	PC Board Assembly, Control-DC
584-335	14	pc, board, assy., ballast
936-247	15	Power Entry Assy
246-231-0024	16	Power supply, 24v@150w,chassis
656-190	17	Panel Assy, Control, MD490S Membrane Panel
489-798-0032	21	washer, flat, nylon
146063600	22	LABEL-"DANGER HIGH VOLTAGE"2.5
311-191-9393	23	FAN GUARD, METAL WIRE 3 5/8 IN

Parent Item 931-124	VACUUM ASSEMBLY MD-490S	
P/N	REF	DESCRIPTION
651-150	1	mass spectrometer ass'y
652-149	2	Manifold Assy, MD490S
353-691-1015	4	Turbo Pump, W/ rotation mod.
631-117	6	Pump Assembly, KNF w/ Vent PORT, Valve & Connector
464-091-0002	7	Pump Mounting Plate Weldment
464-091	8	SPEC TUBE BRACKET WELDMENT
442-094-2036	9	clamp, nw-10/16, low-clearance
441-091-2008	10	seal ring, nw-10
442-094-2011	15	clamp, nw-40, alum
482-091-1012	16	bumper, vibration isolator
354-691-0008	18	adapter, pump, turbo, nw-10 to 1/8
175004600	19	TUBING 1/4 OD POLY-FLOLENE
485-092-5053	20	FITTING Banjo Assy, G1/4-Hose
485-092-5054	21	Tube Fitting Assy, G1/4 - G1/4
914-144-0001	22	Rod, Threaded

Parent Item 651-150 mass spectrometer ass'y

**MANUAL- MD-490S PORTABLE HELIUM LEAK DETECTOR**

P/N	REF	DESCRIPTION
651-132	1	source ass'y,
651-302	2	collector ass'y
751-112	3	mass spectube body/shell s/s
751-104	4	MAGNET ASSEMBLY, SPEC. TUBE
451-613-1049	5	PLATE, SHELL BAFFLE
489-114-0005	6	screw, 4-40 x 3/16"lg vented s/s flstr hd slotted
489-116-0014	7	screw, 10-32 x 5/8"lg. st.stl.
489-111-1007	8	screw, 6-32 x 1/2" lg, socket HEAD CAP S/S
489-798-0049	9	washer,flt.205id.440od,.065thk ST/STL

Parent Item 652-149      Manifold Assy, MD490S

P/N	REF	DESCRIPTION
452-681-1045	1	MANIFOLD
492-092-2010	2	o ring, buna-n, ind.#2-010
489-798-0039	3	washer,neopr,031tk.203id.443od
452-691-1024	6	Aperture, Pinhole, 40 Micron
452-681-1032	7	MANIFOLD, MASS SEPERATOR
485-091-6028	8	orifice, .012, 1/8 barb, 10-32
489-798-0018	10	washer, flat #4 id s/s.,4-40
492-092-2006	11	o ring, buna-n, ind# 2-006
673-114	12	Valve Assy, Probe, MD490S
489-115-0022	13	screw,4-40x1 1/8"pan head,phil
452-611-1025	15	FLANGE, MANIFOLD MOUNT
489-116-0021	16	screw,6-32x3/4",soc. cap, s/s
489-798-0041	17	Washer,plastic,10-32x2mm thk
424-051-0006	21	BLOCK, FLOW CONTROL
189047000	22	VALVE, 1/4" SPEED CONTROLLER
162126700	23	ELBOW, MALE, 1/4 TUBE TO 1/8 N
492-092-2012	24	o ring, buna-n, ind.#2-012
011-213-1501	25	tube,tygon,1/4"od x 1/8"id
412-090-0008	26	CLAMP, PC BOARD SUPPORT
133093301	27	BELLEVILLE WASHER.115ID .250OD

Parent Item 936-163      Cable Package, MD490S-CE

P/N	REF	DESCRIPTION
685-006	10	Cable Assy, Display to Alpha (20-Conductor)
872-805	20	Cable Assy, Audio Signal
872-903	30	Cable Assy, Ballast Board
872-904	40	Cable Assy, Display Ribbon
872-905	50	Cable Assy, Source
872-906	60	Cable Assy, Collector
872-908	70	Cable Assy, Backing/Transport Pump
872-909	80	Cable Assy, Power Supply A/C Input
872-910	90	Cable Assy, Power Supply Outpt
872-912	100	Cable Assy, Key Lock
872-915	110	Cable Assy, RS485
872-913	120	Cable Assy, Probe Valve
872-914	130	Cable Assy, CPU-DC Power
872-923	140	Cable Assy, Control-DC Power

Parent Item 752-150      calibrator, mo-5 typeGAS LEAK

P/N	REF	DESCRIPTION
-----	-----	-------------

**MANUAL- MD-490S PORTABLE HELIUM LEAK DETECTOR**

473-291-1001	2	valve,filler,cal. leak std
419-693-3009	3	cylinder, calib. leak, 150cc
921-101	4	metal orifice leak element

Parent Item 936-247	Power Entry Assy	
P/N	REF	DESCRIPTION
366-405-0004	1	Switch, Power Entry, 2-Pole
387-012-0003	2	cable, main power
013-218-5063	3	cable, 18/3, pvc jacket
388-100-0001	4	Terminal Block, Single
388-313-0103	5	Terminal, End Anchor, Mounting
388-711-1004	6	jumper, internal mini 4 pole
388-711-1006	7	Jumper, Internal, Mini, 2-Pole
388-313-0028	8	terminal, wire ferrule, 18 awg
388-313-0003	10	terminal, ring tongue 16-14 ga
331-111-0031	16	FUSE 3.15A,5X20mm, Time Delay
331-210-3002	17	fuse holder, panel mount 5x20
398-093-0007	18	mounts, adhesive backed, 4 way
398-093-0010	19	mount, flat cable, adhesive
013-118-3013	20	Wire, 18awg, Stranded
388-221-4362	22	TERMINAL BLOCK, 24-10AWG
388-221-2018	23	TERMINAL BLOCK, DISC.
388-221-2019	24	terminal, fuseholder, plug in
331-111-0020	25	fuse, 5x20 mm 1 amp 250v
388-221-1011	26	end anchor, phoenix only
398-091-0007	27	RAIL, relay mount

Parent Item 656-190	Panel Assy, Control, MD490S Membrane Panel	
P/N	REF	DESCRIPTION
719-401	1	Membrane keypanel assy
584-330	2	pc, board, assy., display bd.
583-336	3	pcb assy, alphanumeric display
292-091-0056	4	insulator,fish paper for vfd
493-096-1009	5	standoff, l.e.d. mount
493-096-1027	6	spacer,round,.219id,3/8od3/8L

Parent Item 658-109	SNIFFER PROBE, STANDARD	
P/N	REF	DESCRIPTION
741-116	1	filter ass'y, sniffer probe, SEE 741-117 for box quant.
455-612-1078	2	probe body machining
658-103	3	probe tip assy & details
492-092-2006	4	O-RING, buna-n, ind# 2-006
413-613-1003	5	filter, super sniffer s/s
658-104	6	filter housing ass'y & details
487-691-1005	7	connector, flex-protecting
011-213-1507	8	tube,pvc,opaque red .031 id
369-321-0007	9	snub bushing,1/4 dia tube
754-111	10	adaptor,probe end, assy
489-798-0041	11	washer,plastic,10-32x2mm thk



## APPENDIX 1- COMMUNICATION OPTION

This option allows an ASCII type terminal, desktop computer or a Programmable Logic Controller to remotely monitor and control the leak detector unit using a standard RS-232 serial interface. It also enables the external printing function, which uses the PRINTER connector on the unit rear panel. All panel functions and menus are duplicated on the remote terminal. A virtual interface incorporating a graphical screen is displayed on the remote monitor. The actual software protocol is simple and concise, making it ideal for integrating into a current operating system.

### REQUIREMENTS:

- a) Program ROM chipset with the COMM/PRINT option enabled.
- b) Null Modem RS-232 cable with DB-9 on MD490S side.
- c) A host computing system able to emulate ASCII protocol and having RS232 serial port availability.

### PROTOCOL DEFINITIONS:

<CR> - ASC11 13 = Carriage return  
<LF> - ASC11 10 = Line Feed

### PROTOCOL REQUIREMENTS:

1. The leak detector will accept three commands:
  - a. FUNCTION command
  - b. EDIT or SET command
  - c. ENQUIRY command
2. All command strings must end with <CR><LF>.
3. All command strings are acknowledged after <CR><LF>.
4. The host must wait until a confirmation prompt is received before transmitting.
5. All data parameters transferred will follow a specific data format.
6. Set RS232C port parameters to:
  - a. Baud = 9600
  - b. Parity = NONE
  - c. Data = 8 bits
  - d. Stop bits = 1

**COMMAND STRING FORMAT:**

1. FUNCTION COMMAND: <F><TYPE><CR><LF>
2. ENQUIRY COMMAND: <E><TYPE><CR><LF>
3. EDIT/SET COMMAND: <S><TYPE><=><PARAMETER><CR><LF>

**ACKNOWLEDGE PROMPTS:**

- "=>"            No errors were detected and the command was successfully parsed and executed.
- "?>"            A COMMAND ERROR was detected. The command was not executed because it was not understood. For instance, this prompt would be returned if the leak detector was sent a command string, that contained a syntax error.
- "!>"            An EXECUTION ERROR was detected. The command was understood but not executed. Parameter out of range or parameter syntax incorrect.

**GETTING STARTED:**

Use a Personal computer with terminal emulation software to test the communication option. Install the serial cable to the COM1 port located on the back of the leak detector.

Each command can be tested by typing the desired command string followed by a <CR><LF>. Start testing the function commands first, for they are the simplest. Below are a few examples:

COMMAND STRING	ACK.	RESULTS
Fa<CR><LF>	=>	TURN SNIFF ON NO ERRORS
Fz<Cr><Lf>	?>	COMMAND ERROR FUNCTION Fz DOES NOT EXIST
Sa=100<CR><LF>	=>	SET GAIN "A" TO 100 NO ERRORS
Sa=250<CR><LF>	!=	SET GAIN "A" TO 250 EXECUTION ERROR (OUT OF RANGE)
Sa=0100<CR><LF>	!=	SET GAIN "A" TO 100 EXECUTION ERROR (PARAMETER TOO LONG)
Ea<CR><LF>	250 =>	ENQUIRE TUNE VOLTS NO ERRORS

The following are commands to inquire about system parameters.

<b>ENQUIRY COMMANDS</b>			
<b>CMDS</b>	<b>DESCRIPTION</b>	<b>DATA FORMAT</b>	<b>VALID RANGE</b>
Ea	TUNE VOLTS	<XXX>	217-277
Eb	STF VOLTS	<XXX>	TUNE-70
Ec	A-PLATE VOLTS	<XXX>	TUNE-100
Ed	C-PLATE VOLTS	<-XXX>	100-200
Ee	S-PLATE VOLTS	<XXX>	150-250
Ef	EMISSION CURRENT (mAMPS)	<X.XX>	0.50-2.50
Eg	FILAMENT CURRENT (amps)	<X.X>	0.0-4.0
Eh	GAIN (FILAMENT "A")	<XXX>	049-201
Ei	GAIN (FILAMENT "B")	<XXX>	049-201
Ej	TURBO SPEED (%)	<XXX>	000-100
Ek	CALIBRATED LEAK (cc/sec)	<X.XESXX>	1.0E-6 - 9.9E-3
El	BALLAST PRESSURE (Torr)	<XXX>	000-999
Em	BALLAST PRESSURE S.P.(Torr)	<XXX>	000-760
En	LEAK RATE (cc/sec)	<SX.XE-XX>	0 - 1.0E-02 Can go NEG.
Eo	SETPOINT #1	<X.XE-XX>	1.0E-6 - 9.9E-3
Ep	SETPOINT #2	<X.XE-XX>	1.0E-6 - 9.9E-3
Eq	MECH. & TURBO PUMP HOURS	<XXXXX>	0 - 99999
Er	FIL "A" & FIL "B" HOURS	<XXXXX>	0 - 99999
Es	16 DISCRETE FAULTS SEE FAULT DESCRIPTION	<XXXXX>	0-65535
Et	COLLECTOR VOLTS	<SXX.XX>	-10.00 - 10.00
?	<b>HELP MENU</b>	1000 bytes	

**MANUAL- MD-490S PORTABLE HELIUM LEAK DETECTOR**

The following are commands to set or edit system parameters.

<b>SET/EDIT COMMANDS</b>			
<b>CMDS</b>	<b>DESCRIPTION</b>	<b>DATA FORMAT</b>	<b>VALID RANGE</b>
Sa	GAIN FILAMENT "A"	<XXX>	050-200
Sb	GAIN FILAMENT "B"	<XXX>	050-200
Sc	CALIBRATED LEAK (cc/sec)	<X.XE-XX>	1.0E-6 - 9.9E-3
Sd	SETPOINT #1 (cc/sec)	<X.XE-XX>	1.0E-6 - 9.9E-3
Se	SETPOINT #2 (cc/sec)	<X.XE-XX>	1.0E-6 - 9.9E-3
Sf	BALLAST PRESSURE S.P.(Torr)	<XXX>	000 - 760
Sg	TUNE VOLTAGE	<XXX>	218 - 277
Sh	AUDIO VOLUME	<XXX>	000 - 100
Si	EMISSION (mAMPS)	<X.XX>	0.50 - 2.50

The following are commands to enable or disable system functions.

<b>FUNCTION COMMANDS</b>	
<b>CMDS</b>	<b>DESCRIPTION</b>
Fa	SNIFF ON
Fb	SNIFF OFF
Fc	AUTO ZERO
Fd	FILAMENT A/B
Fe	CALIBRATE
Ff	START UP
Fg	SHUTDOWN
Fh	STANDBY
Fi	FILAMENTS ON
Fj	FILAMENTS OFF
Fk	AUTO SEND LEAK RATE ON
Fl	AUTO SEND LEAK RATE OFF

**FAULT DESCRIPTION:**

An unsigned integer is transferred to describe system faults. It has a range of 0-65535 in base 10. Using base 2, we need 16 bits to represent this number. Each bit will represent a system fault as described in Section 10.1, Alphanumeric Display.

- B0** - High Board temp (low order bit)
- B1** - Turbo speed
- B2** - Filament Current
- B3** - A-Plate voltage
- B4** - STF Plate voltage
- B5** - S-Plate voltage
- B6** - C-Plate voltage
- B7** - Emission fault
- B8** - Tune Voltage fault
- B9** - Probe Blocked fault
- B10** - Collector Saturated
- B11** - In Sniff and Filaments OFF
- B12** - Gain Error
- B14** - PUMPDOWN timeout
- B15** - Ballast Transducer fault
- B16** - Zero Collector watchdog fault (high order bit)

**PRINTING FUNCTION**

MENU #2, sub-menu PRINT MODE allows the setup of the desired method of printing. The three (3) printing modes are OFF, LOG and LABEL and described as follows:

- OFF:** The printing function is disabled.
- LOG:** The printing function is configured to print to a standard dot matrix type printer through the PRINTER PORT on the unit rear panel.
- LABEL:** The printing function is configured to print to a standard dot matrix type printer setup with standard 3-1/2" x 15/16" tractor feed labels.

Printing is initiated by pressing the ENTER key on the front panel. The information printed is the actual leak rate, at the time the key is pressed, and a PASS or FAIL result. The criteria for pass or fail is based on the value of setpoint #1 (SP#1) as follows:

IF THE RESULTING LEAK RATE IS GREATER THAN SET-POINT #1, A FAIL IS PRINTED.

IF THE RESULTING LEAK RATE IS LESS THAN SET-POINT #1, A PASS IS PRINTED.

**APPENDIX 2- LEAK RATE ANALOG OUTPUT OPTION**

Analog leak rate signals are accessed via a screw terminal located on the back panel. Three (3) signal types are provided:

**TYPE 1. LEAK RATE (PIN 1.)**

This signal is linear with respect to leakage and has two (2) analog level settings and three (3) sensitivity scale factors. The signal source is a Digital to Analog converter located on the CPU board. Output resolution is 12 bits (4095 counts).

Analog level settings are set via CPU jumper JP1.

- 0 - 10 volts    JP1 open
- 0 - 5 volts    JP1 shorted

Scale factors are set via the menu accessed from the front panel. The scale factor screen is located under the "system setup" group. Scale factor setting determine the sensitivity of the analog output with respect to the leak rate magnitude. Setting of  $10E^{-6}$ ,  $10E^{-5}$  and  $10E^{-4}$  ranges are available. Maximum analog output voltage will be asserted when the leak rate is equal to 10 times the scale factor selected.

ANALOG OUT MAX. (LEAK RATE)	LEAK RATE SPAN	MAXIMUM OUTPUT LEVEL	JP1 SHORTED
		JP1 OPEN	
$10E^{-6}$	0 - $10 \times 10E^{-6}$	0 - 10V	0 - 5V
$10E^{-5}$	0 - $10 \times 10E^{-5}$	0 - 10V	0 - 5V
$10E^{-4}$	0 - $10 \times 10E^{-4}$	0 - 10V	0 - 5V

**TYPE 2. METER OUTPUT (PIN 2.)**

For remote leak rate signal indication, connect a needle meter between connection points meter out and ground. Jumper JP1 sets the maximum drive current for the meter.

- 0 - 1 milliamp                      JP1 open
- 0 - 0.5 milliamp                  JP1 shorted

**TYPE 3. COLLECTOR OUTPUT (PIN 3.)**

This signal is the raw leak rate signal taken directly from the ion collector amplifier. Signal magnitude is not affected by scale factor settings. Normally this signal is used during troubleshooting, or to obtain high-resolution information. The output signal is nonlinear and follows the formula given below:

$$\text{leak rate} = 10 - \text{vcol} / (5 \times 10^6) \times (\text{emsp} - (10 - \text{vcol} / 20)) \times \text{emsp}$$

where emsp = the emission setpoint.

APPENDIX 3 - REMOTE I/O OPTION

This option allows basic signals to be communicated between the unit and a PROGRAMMABLE LOGIC CONTROLLER for the purpose of automatic control by using the REMOTE I/O connector on the unit rear panel. Signal control can be AC or DC, depending on the particular option you have ordered. The functions that can be automatically controlled are as follows:

**OUTPUTS:**

**SET-POINT #1:** A signal is sent from the unit if the resulting leak rate is greater than this setpoint.

**SET-POINT #2:** A signal is sent from the unit if the resulting leak rate is greater than this setpoint.  
**With option 918 – 502 and 918 – 503 only.**

**READY:** A signal is sent from the unit if three conditions are met:

1. No faults have occurred.
2. The unit is in TEST mode.
3. The filaments are ON.

**INPUTS:**

**AUTO-ZERO:** An active high pulse applied to this line will cause the unit to perform an AUTO-ZERO function.

**SNIFF CONTROL:** An active high state applied to this enables sniff mode.  
**With Option 918-507 and 918-508 only.**

**SIGNAL CHARACTERISTICS:**

There are two (2) types of signals available, DC or AC. The type of signal depends on the exact option ordered.

**AC SIGNAL:** All input and output signals are 115 VAC and defined as follows:

**OUTPUT:**

Status driven with an active status drive. Therefore, the presence of a particular signal indicates that the condition is true and will remain true until it changes and causes it to be inactive. For example, if the unit is ready, the READY line will have 115 VAC present with respect to the COMMON line. No more than 1 amp of current can be drawn on each signal line. This is enough to directly drive a relay, low current bulb or PLC AC module input.



**INPUT:**

Pulse driven with an active pulse drive. The AC pulse must be between 0.2 and 1.0 seconds in duration to enable the function. For example, to perform an AUTO-ZERO function, place a 0.5second duration, 115 VAC pulse on this line. Sniff control requires a constant active state to enable sniff mode.

**DC SIGNAL:**

All input and output signal levels are defined as follows:

**OUTPUT:** 5 - 60 VDC

**INPUT:** 10 - 32 VDC

Signal characteristics are defined as follows:

**OUTPUT:**

Level driven with an high level drive. Therefore, a high level on a particular line indicates that the condition is true and will remain true until it changes and causes the level to go to a low level. For example, if the unit is ready, the READY line will have 5 - 60 VDC level with respect to the GROUND line. No more than 1 amp of current can be drawn on each signal line. This is enough to directly drive a relay, low current bulb or PLC DC module input.

**INPUT:**

Pulse driven with an active pulse drive. The DC pulse must be between 0.2 and 1.0 seconds in duration to enable the function. For example, to perform an AUTO-ZERO function, place a 0.5 second duration, 10 - 32 VDC pulse on this line. Sniff control requires a constant active state to enable sniff mode.

## NOTICE

THE TURBO-TEST MD-490S UTILIZES A FIXED RESERVOIR INTERNAL CALIBRATED GAS LEAK FOR PURPOSES OF SYSTEM CALIBRATION. THIS LEAK STANDARD HAS A 10% FALL-OFF LIFE AS INDICATED ON THE ATTACHED CERTIFICATE OF CALIBRATION. FOR THIS EQUIPMENT TO PROPERLY FUNCTION, IT IS RECOMMENDED THAT THE CALIBRATED GAS LEAK BE RETURNED TO VACUUM INSTRUMENT FOR RE-CALIBRATION PRIOR TO THE 10% FALL-OFF DATE AS DOCUMENTED ON THE ENCLOSED CERTIFICATE OF CALIBRATION.



**VIC Leak Detection**

Industrial Leak Detection  
Air Leak Testing  
Vacuum Metrology

Vacuum Instrument Corporation  
**2099 Ninth Avenue, Ronkonkoma, NY 11779**  
**Tel # (631) 737-0900 – Fax # (631) 737-1541**  
www.vicleakdetection.com - sales@vicleakdetection.com

**Sales/Service Offices**  
**California, New York, Ohio,**  
**Mexico, France, Germany, Japan**

Exclusive Sales & Service Representatives Worldwide

Vacuum Instrument Corporation has the broadest experience with comprehensive leak detection solutions required to design, build, sell, and service the most innovative and versatile leak detectors anywhere in the world. That is because leak detection is and always has been our only business. We are dedicated to leak detection, and our customers have made us the largest leak detector company in the world.

THIS DRAWING IS FURNISHED FOR INFORMATION AND REFERENCE ONLY. THE FURNISHING OF THIS DRAWING DOES NOT CONVEY ANY REPRODUCTION OR MANUFACTURING RIGHTS.

DWG. NO.		1		
ZONE	REV.	DESCRIPTION	DATE	APPROVED
A		TRANSFERRED TO CADD	9/29/97	IAM
		ADDED (2) ITEM #16		
		REMOVED (1) ITEM #16		

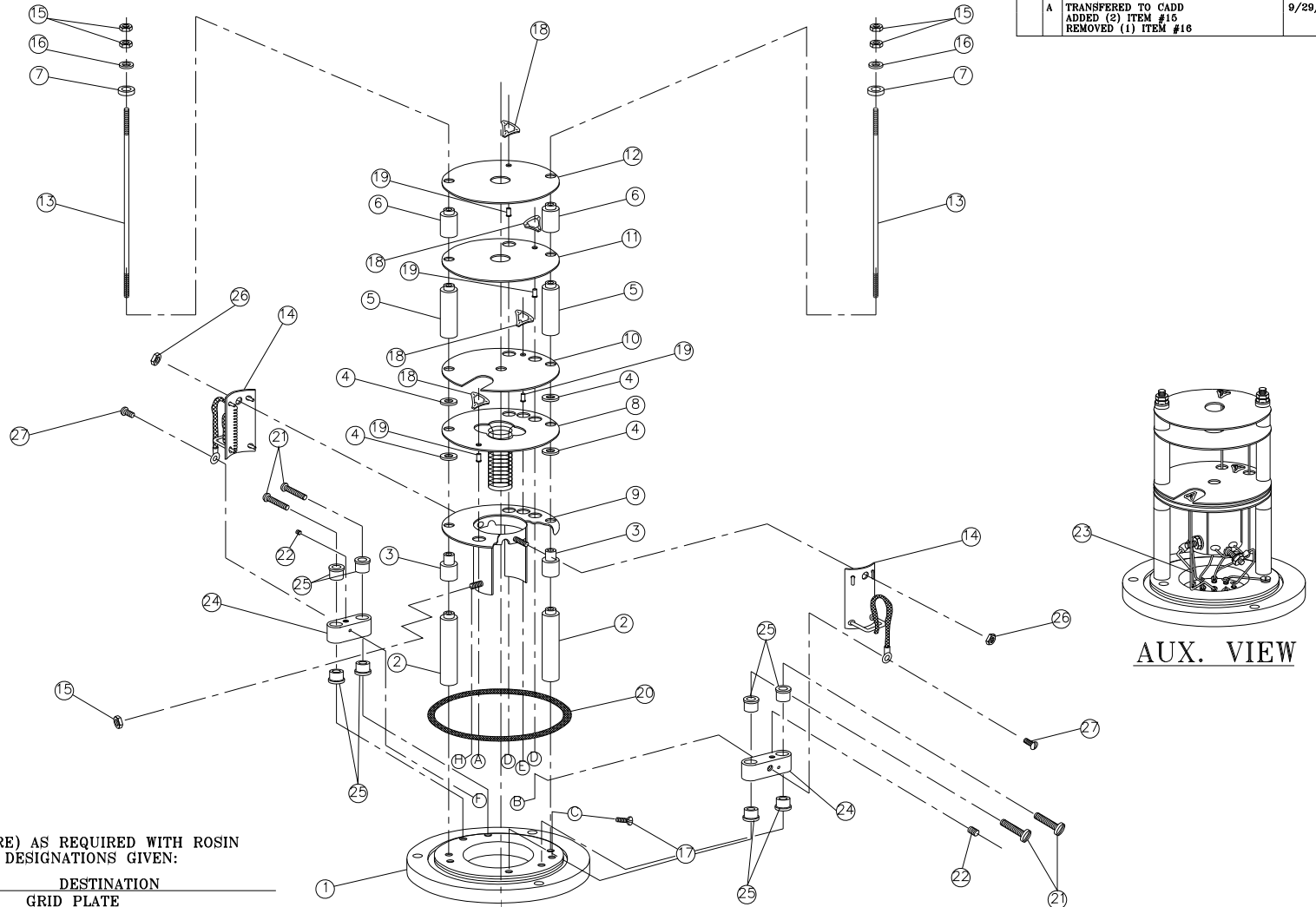

**NOTE(s):**

1) USE ITEM #23 (BUS WIRE) AS REQUIRED WITH ROSIN CORE 60/40 SOLDER BY DESIGNATIONS GIVEN:

LETTER	PIN NO.	DESTINATION
A	1	GRID PLATE
C	3	FLANGE GROUND

PARTS LIST FOR THE 651-132  
SOURCE ASSEMBLY

DWG # 651-132 - SOURCE ASS'Y, MD-490 SERIES LEAK DETECTORS. (DY)				
REF.#	DESCRIPTION	PART #	QTY.	UNIT
1	FLANGE ASS'Y, UNIVERSAL, SPEC TUBE,MD-290T PORTABLE (BY)	651-130	1	EA
2	STANDOFF, SOURCE, S/S, PORTABLE (AY)	451-612-1024	2	EA
3	STANDOFF, INSULATING,.312 DIA. X .437 LG. CERAMIC (AN)	451-612-1003	2	EA
4	WASHER, INSULATOR, VIC SOURCE, .31 DIA.X .030 THK.TORLON (AY)	451-612-1004	4	EA
5	STANDOFF, SOURCE, CERAMIC, PORTABLE (AN)	451-612-1026	2	EA
6	STANDOFF, INSULATING, VIC SOURCE ITEM 22 (AN)	451-612-1006	2	EA
7	CAP, END, TORLON, PORTABLE (AY)	451-612-1028	2	EA
8	GRID ASS'Y, ACCELERATION VIC SOURCE (CN)	651-111	1	EA
9	CONTAINMENT ASS'Y, VIC SOURCE (BY)	651-112	1	EA
10	PLATE, "A", VIC SOURCE, ITEM 19 (AY)	451-612-1021	1	EA
11	PLATE, "B", VIC SOURCE , ITEM 21 (AY)	451-612-1013	1	EA
12	PLATE, "C", VIC SOURCE, ITEM 23 (AY)	451-612-1012	1	EA
13	ROD, THREADED,COLLECTOR/SOURCE 4-40 THREAD X 3.43 LG.,S/S(AY)	451-613-1073	2	EA
14	FILAMENT KIT, BOX OF 4,SINGLE FILAMENT ASS'Y (N)	919-128	1	BX
15	NUT, 4-40 S/S WITH 1/4"HEX DRV	489-218-0008	5	EA
16	WASHER, FLAT #4 ID S/S.,4-40	489-798-0018	2	EA
17	SCREW, 4-40 X 3/16"LG VENTED S/S FLSTR HD SLOTTED	489-114-0005	1	EA
18	RETAINER, TRIANGULAR, SOURCE, WALDES # 5305-6, .0100THK	351-611-1003	4	EA
19	BOOT, WIRE END, SOURCE ASSY. AMP # 1-331677-4	351-611-1002	4	EA
20	O RING, BUNA-N, PARKER #2-144	492-092-2144	1	EA
21	SCREW, 4-40 X 5/8"LG FLSTR HD PHILLIPS	489-114-0007	4	EA
22	SCREW, SET, 4-40 X 1/4"LG S/S CUP POINT, SKT DRIVE	489-118-0004	2	EA
23	WIRE, BUS 20 GAUGE U/M FEET	013-120-9001	1	FT
24	TERMINAL BLOCK, FILAMENT, VIC SOURCE, ITEM 4 (BY)	451-612-1010	2	EA
25	INSULATOR, VIC SOURCE , ITEM 3 (AY)	451-612-1007	8	EA
26	NUT, 4-40 S/S WITH 3/16"HEX DR	489-218-0009	2	EA
27	SCREW, 4-40, 5/16"LG PAN HD S/S	489-116-0009	2	EA

THIS DRAWING IS FURNISHED FOR INFORMATION AND REFERENCE ONLY. THE FURNISHING OF THIS DRAWING DOES NOT CONVEY ANY REPRODUCTION OR MANUFACTURING RIGHTS.

REVISIONS			
REV.	DESCRIPTION	DATE	APPROVED
A	REMOVED ITEMS #15,19,20,21, ITEM #18 WAS 011-213-3628, ECD 485	12/5/00	ANH
B	ADDED CALL OUTS FOR #22 THRU 27 CLARIFY ASSY OF CAP, ECD 494	12/21/00	ANH
C	BORE ITEM #2 DEEPER, ECD 502	3/22/01	
D	REMOVED ITEMS #29,30 (UPDATED DESCRIPTION & BOM TO READ "PROBE ONLY") ECD#578	10/12/04	

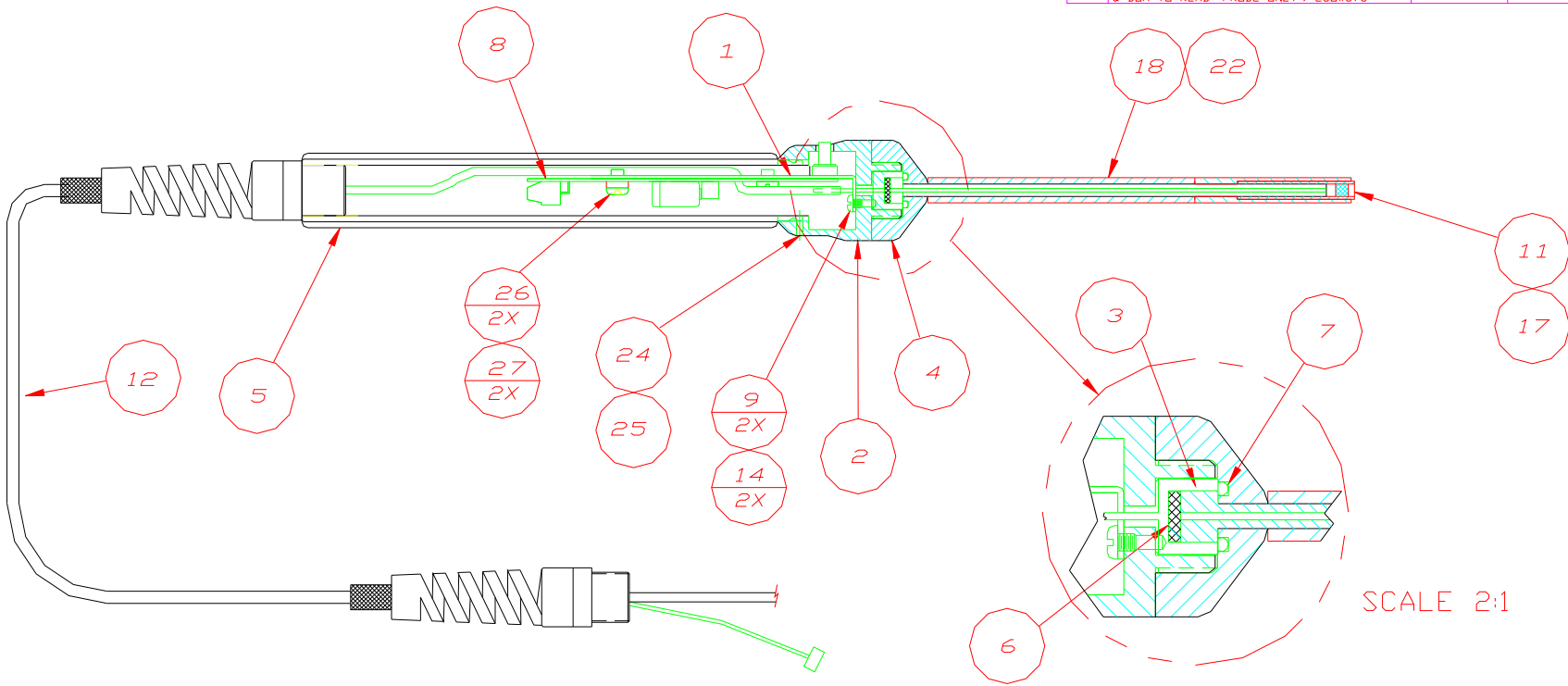

DWG. NO. 658-105  
SHEET 1 OF 1  
REV. C

ITEM	QTY	PART OR IDENTIFYING NO.	NOMENCLATURE OR DESCRIPTION	MATERIAL SPECIFICATIONS
PARTS LIST				
UNLESS OTHERWISE SPECIFIED DIMENSIONS ARE IN INCHES TOLERANCES ARE: FRACTIONS DECIMALS ANGLES $\pm \frac{1}{64}$ .XX $\pm$ 0.01 $\pm$ 1° .XXX $\pm$ 0.005			CUSTOMER <b>MD490S</b>	<b>VACUUM INSTRUMENT CORP.</b> RONKONKOMA, N.Y. 11779
MATERIAL			APPROVALS	DATE
FINISH UNLESS OTHERWISE SPECIFIED 125			DRAWN: <i>BCB</i>	12/8/00
DO NOT SCALE DRAWING			CHECKED	
			PRODUCTION	
			ENGINEERING	
SCALE 1 = 1		FILE # 658-105C	SIZE B	DWG. NO. 658-105
			SHEET 1 OF 1	REV. D

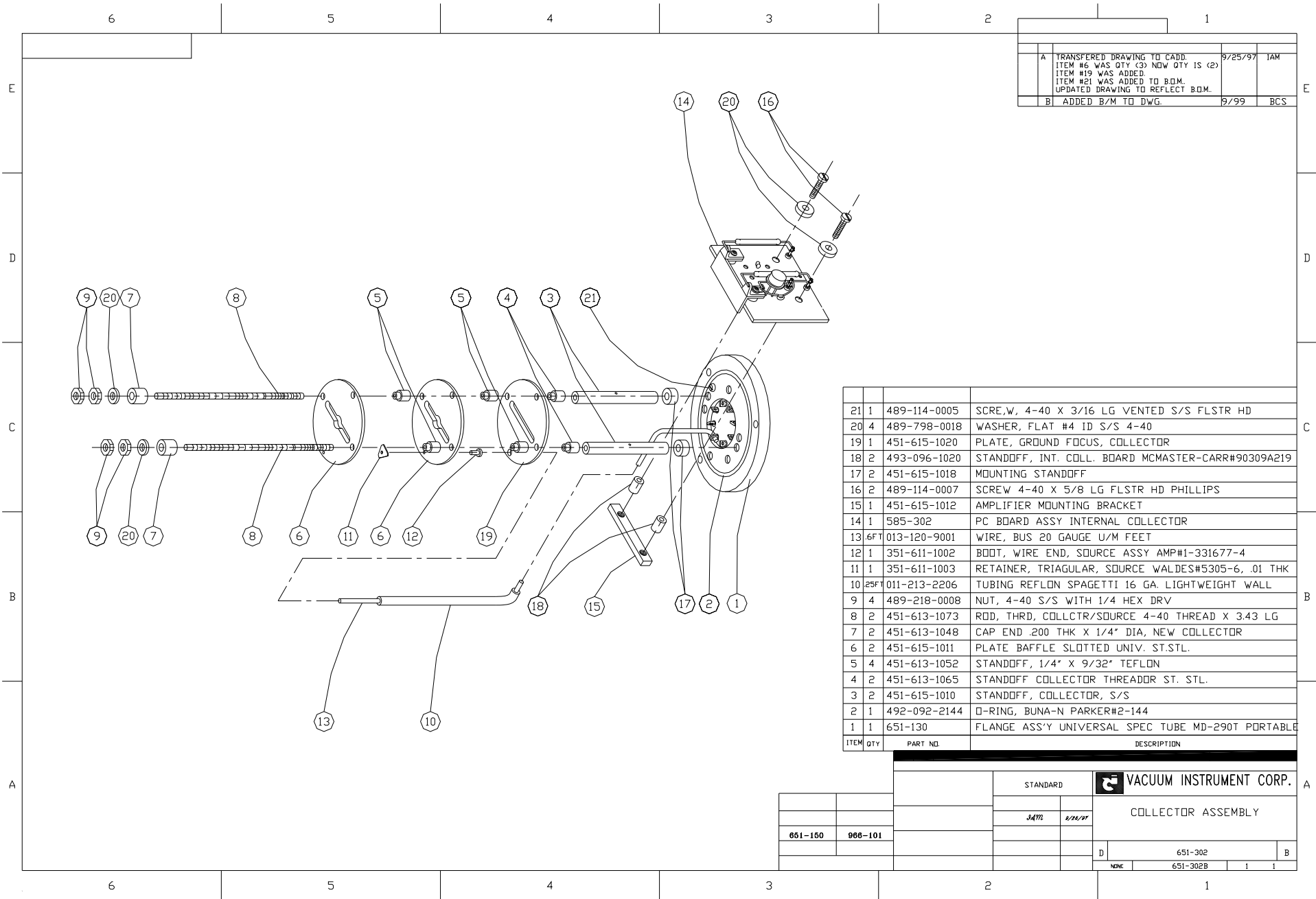

A	TRANSFERED DRAWING TO CADD. ITEM #6 WAS QTY (3) NOW QTY IS (2) ITEM #19 WAS ADDED. ITEM #21 WAS ADDED TO B.O.M. UPDATED DRAWING TO REFLECT B.O.M.	9/25/97	JAM
B	ADDED B/M TO DWG.	9/99	BCS

21	1	489-114-0005	SCRE,W, 4-40 X 3/16 LG VENTED S/S FLSTR HD
20	4	489-798-0018	WASHER, FLAT #4 ID S/S 4-40
19	1	451-615-1020	PLATE, GRDUND FOCUS, COLLECTOR
18	2	493-096-1020	STANDOFF, INT. COLL. BOARD MCMASTER-CARR#90309A219
17	2	451-615-1018	MOUNTING STANDOFF
16	2	489-114-0007	SCREW 4-40 X 5/8 LG FLSTR HD PHILLIPS
15	1	451-615-1012	AMPLIFIER MOUNTING BRACKET
14	1	585-302	PC BOARD ASSY INTERNAL COLLECTOR
13	6F	013-120-9001	WIRE, BUS 20 GAUGE U/M FEET
12	1	351-611-1002	BOOT, WIRE END, SOURCE ASSY AMP#1-331677-4
11	1	351-611-1003	RETAINER, TRIAGULAR, SOURCE WALDES#5305-6, .01 THK
10	25F	011-213-2206	TUBING REFLON SPAGETTI 16 GA. LIGHTWEIGHT WALL
9	4	489-218-0008	NUT, 4-40 S/S WITH 1/4 HEX DRV
8	2	451-613-1073	RDD, THRD, COLLECTR/SOURCE 4-40 THREAD X 3.43 LG
7	2	451-613-1048	CAP END .200 THK X 1/4" DIA, NEW COLLECTOR
6	2	451-615-1011	PLATE BAFFLE SLOTTED UNIV. ST.STL.
5	4	451-613-1052	STANDOFF, 1/4" X 9/32" TEFLON
4	2	451-613-1065	STANDOFF COLLECTOR THREADDOR ST. STL.
3	2	451-615-1010	STANDOFF, COLLECTOR, S/S
2	1	492-092-2144	O-RING, BUNA-N PARKER#2-144
1	1	651-130	FLANGE ASS'Y UNIVERSAL SPEC TUBE MD-290T PORTABLE

ITEM	QTY	PART NO.	DESCRIPTION
<b>VACUUM INSTRUMENT CORP.</b>			
COLLECTOR ASSEMBLY			
			D 651-302
			NONE 651-302B 1 1

651-150	988-101
---------	---------

THIS DRAWING IS FURNISHED FOR INFORMATION AND REFERENCE ONLY. THE FURNISHING OF THIS DRAWING DOES NOT CONVEY ANY REPRODUCTION OR MANUFACTURING RIGHTS.

REVISIONS			
REV	DESCRIPTION	DATE	APPROVED
A	ADDED ITEM #11	6/97	BCH
B	ADDED B/M TO DWG.	9/99	BCS

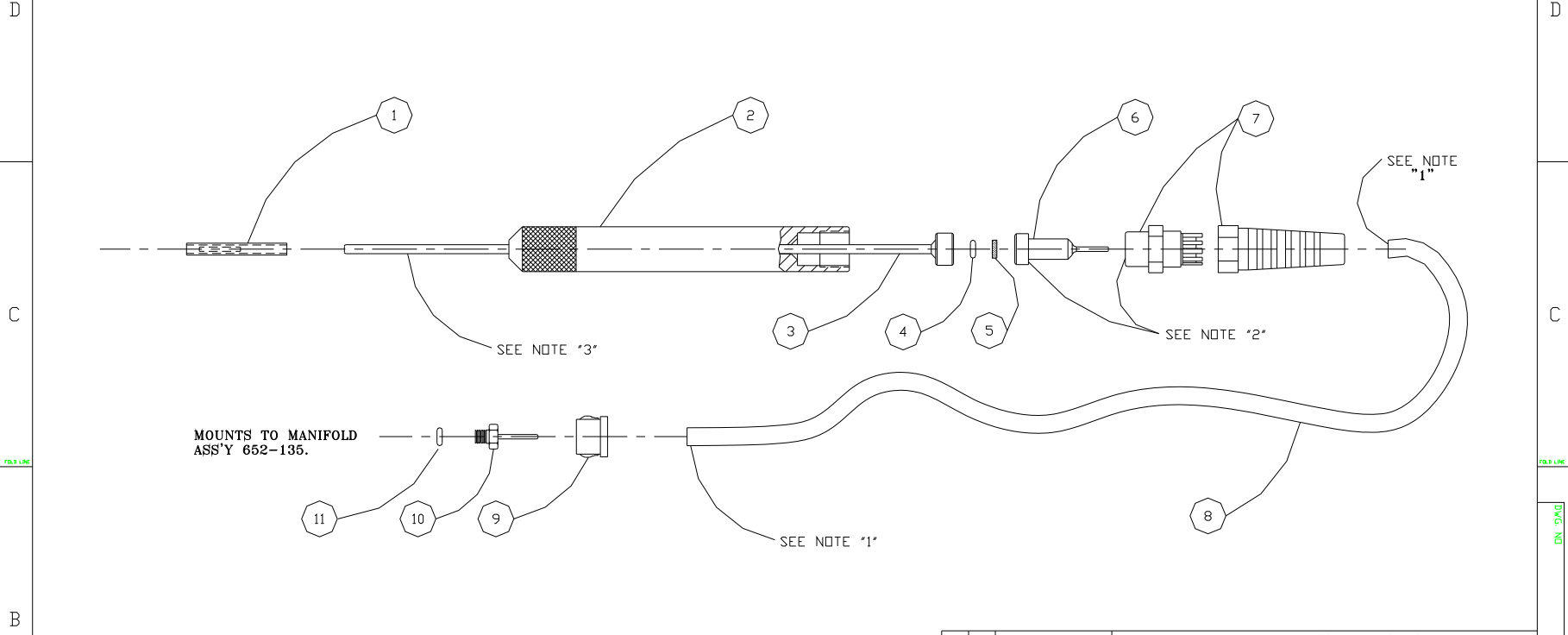

MOUNTS TO MANIFOLD ASS'Y 652-135.

NOTE(s):

- 1) PREHEAT HOSE ENDS PRIOR TO INSTALLING ONTO ITEM #6 AND #10.
- 2) PRESS FIT ITEM #6 ONTO ITEM #7, MAKE INDICATED SURFACES FLUSH.
- 3) APPLY THIN LAYER OF VACUUM GREASE ONTO PROBE TIP ASSY BEFORE INSTALLING ITEMS #1.

ITEM	QTY	REQD	PART OR IDENTIFYING NO.	ABBREVIATIVE OR DESCRIPTION	MATERIAL SPECIFICATIONS
11	1		489-798-0041	WSHER PLASTIC 10-32X 2MM THK SMC#M5G1	
10	1		754-111	ADAPTOR PROBE END ASSY	
9	1		369-321-0007	SNUB BUSHING, 1/4 DIA TUBE HEYCO#2057 (K500-250)	
8	10FT		011-213-1507	TUBE PVC APAGUE RED .031IDX.2350D NORTONHC-219-D4	
7	1		487-691-1005	CONNECTOR, FLEX-PROTECTING HEYCO#3237	
6	1		658-104	FILTER HOUSING ASS'Y & DETAILS	
5	1		413-613-1003	FILTER SUPER SNIFFER S/S, MOTT#1000-250-.062-40	
4	1		492-092-2006	O-RING, BUNA-N IND#2-006	
3	1		658-103	PROBE TIP ASSY & DETAILS	
2	1		455-612-1078	PROBE BODY MACHINING	
1	1		741-116	FILTER ASS'Y SNIFFER PROBE	

UNLESS OTHERWISE SPECIFIED DIMENSIONS ARE IN INCHES TOLERANCES ARE FRACTIONS DECIMALS ANGLES S XXS S XXS S		CUSTOMER		PARTS LIST	
MATERIAL		STANDARD		VACUUM INSTRUMENT CORP. ROCKY HILL, CT 06467	
FINISH		APPROVALS		SNIFFER PROBE ASSY. MD-390S	
NEXT ASSY		CHECKED <i>JAM</i>		DATE 12/11/95	
USED ON		PRODUCTION		SIZE C DWG. NO 658-101	
APPLICATION		DO NOT SCALE DRAWING		ENGINEERING	
		SCALE 1 = 1		FILE # 658-101B SHEET 1 OF 1	



THIS DRAWING IS FURNISHED FOR INFORMATION AND REFERENCE ONLY. THE FURNISHING OF THIS DRAWING DOES NOT CONVEY ANY REPRODUCTION OR MANUFACTURING RIGHTS.

REVISIONS			
REV.	DESCRIPTION	DATE	APPROVED

# RS232 INTERNAL CABLE

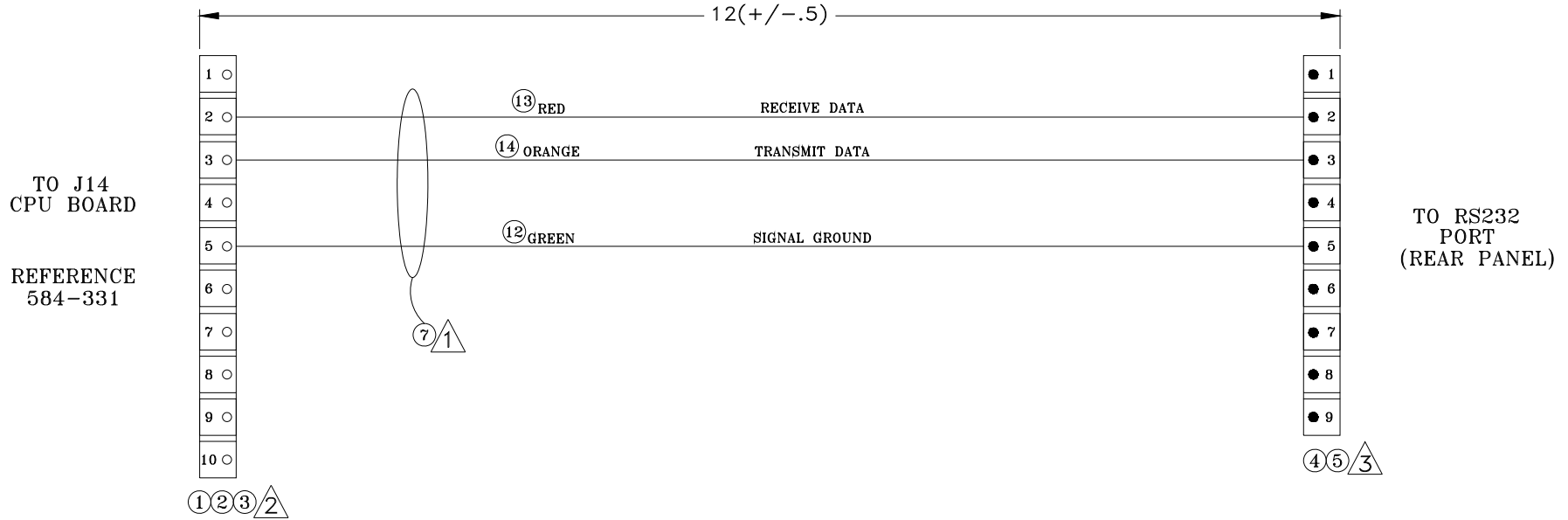

## NOTES

- 1 INSTALL BRAIDING (ITEM#7) OVER WIRES AND CENTER.  
INSTALL 1-inch PIECE OF SLEEVING (ITEM#8) TO ENDS OF BRAIDING, OVERLAP ONTO THE WIRES Min.1/4inch TO Max.1/2inch.
- 2 INSTALL POLARIZATION COVER (ITEM#2) TO ODD NUMBER PINS.  
INSTALL BACK COVER (ITEM#3) TO EVEN NUMBER PINS.
- 3 INSTALLATION OF D-SUB MOUNTING HARDWARE (ITEM#6) UPON INSTALLATION TO DETECTOR.

APPLICATION	USED ON

ITEM	QTY	PART OR IDENTIFYING NO.	NOMENCLATURE OR DESCRIPTION	MATERIAL SPECIFICATIONS
UNLESS OTHERWISE SPECIFIED DIMENSIONS ARE IN INCHES TOLERANCES ARE: FRACTIONS DECIMALS ANGLES ± 1/64 .01 ± .01 ± 1/2° xxx± .005				
MATERIAL			CUSTOMER	PARTS LIST
FINISH UNLESS OTHERWISE SPECIFIED 125			APPROVALS	DATE
APPLICATION			DRAWN <i>MARX</i>	10/00
DO NOT SCALE DRAWING			CHECKED	
			PRODUCTION	
			ENGINEERING	
			SIZE B	DWG. NO. 918-501
			SCALE =	FILE 918-501-1of2- SHEET 1 OF 2



**VACUUM INSTRUMENT CORP.**  
ROCKY HILL, N.Y. 11779

Option, Communication  
Package, RS232, MD490S

THIS DRAWING IS FURNISHED FOR INFORMATION AND REFERENCE ONLY. THE FURNISHING OF THIS DRAWING DOES NOT CONVEY ANY REPRODUCTION OR MANUFACTURING RIGHTS.

# PRINTER CABLE INTERNAL

REVISIONS			
REV.	DESCRIPTION	DATE	APPROVED

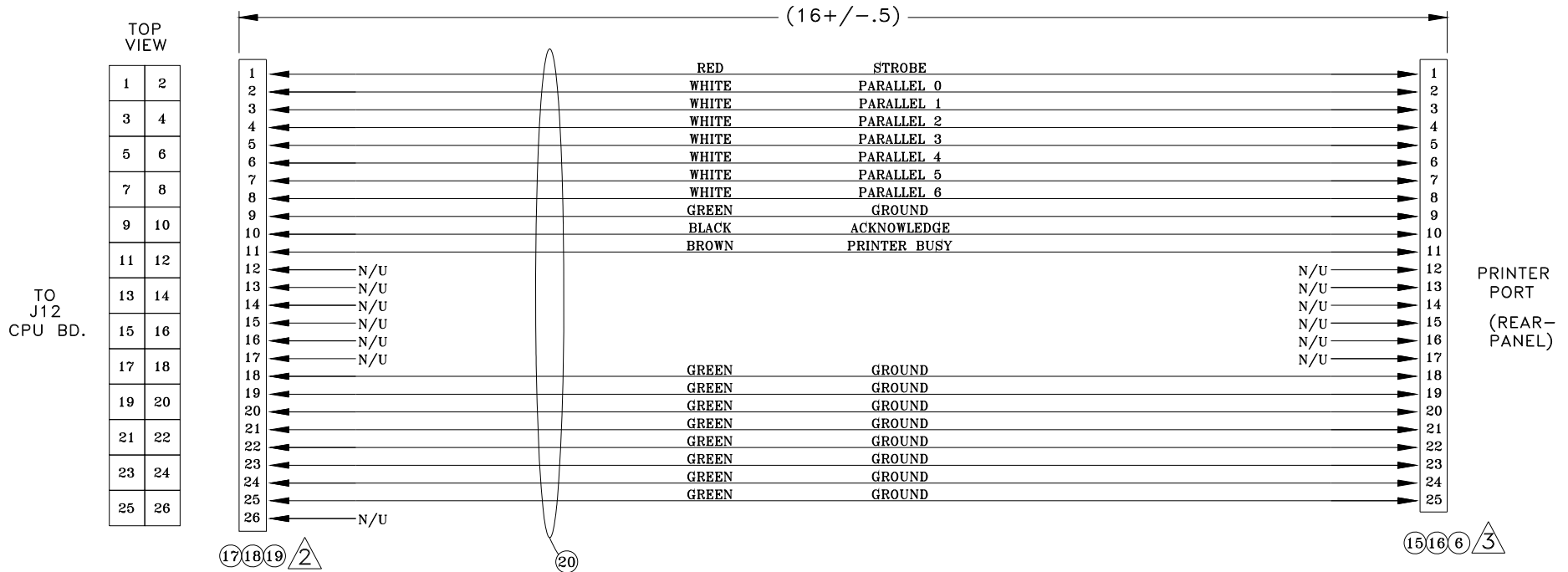

## NOTES

- ① INSTALL BRAIDING (ITEM#20) OVER WIRES AND CENTER. INSTALL 1-inch PIECE OF SLEEVING (ITEM#21) TO ENDS OF BRAIDING OVERLAPPING WIRES Min.1/4inch TO Max.1/2inch.
- ② INSTALL POLARIZATION COVER (ITEM#18) TO ODD NUMBER PINS. INSTALL BACK COVER (ITEM#19) TO EVEN NUMBER PINS.
- ③ INSTALLATION OF D-SUB MOUNTING HARDWARE (ITEM#6) UPON INSTALLATION TO DETECTOR.

ITEM	QTY	PART OR IDENTIFYING NO.	NOMENCLATURE OR DESCRIPTION	MATERIAL SPECIFICATIONS
UNLESS OTHERWISE SPECIFIED DIMENSIONS ARE IN INCHES TOLERANCES ARE: FRACTIONS .01 ± .01 ANGLES ± 1/2° ± 1/64 .xxx± .005				
MATERIAL			CUSTOMER	
FINISH UNLESS OTHERWISE SPECIFIED 125			PARTS LIST	
NEXT ASSY			APPROVALS	
USED ON			DATE	
APPLICATION			DRAWN <i>MARX</i> 10/00	
DO NOT SCALE DRAWING			CHECKED	
			PRODUCTION	
			ENGINEERING	
			SIZE B	
			DWG. NO. 918-501	
			REV. -	
			SCALE =	
			FILE 918-501-2of2-	
			SHEET 2 OF 2	

**VACUUM INSTRUMENT CORP.**  
RONKONKOMA, N.Y. 11779

Option, Communication  
Package, Printer, MD490S

DWG. NO. REV.

THIS DRAWING IS FURNISHED FOR INFORMATION AND REFERENCE ONLY. THE FURNISHING OF THIS DRAWING DOES NOT CONVEY ANY REPRODUCTION OR MANUFACTURING RIGHTS.

REVISIONS			
REV.	DESCRIPTION	DATE	APPROVED

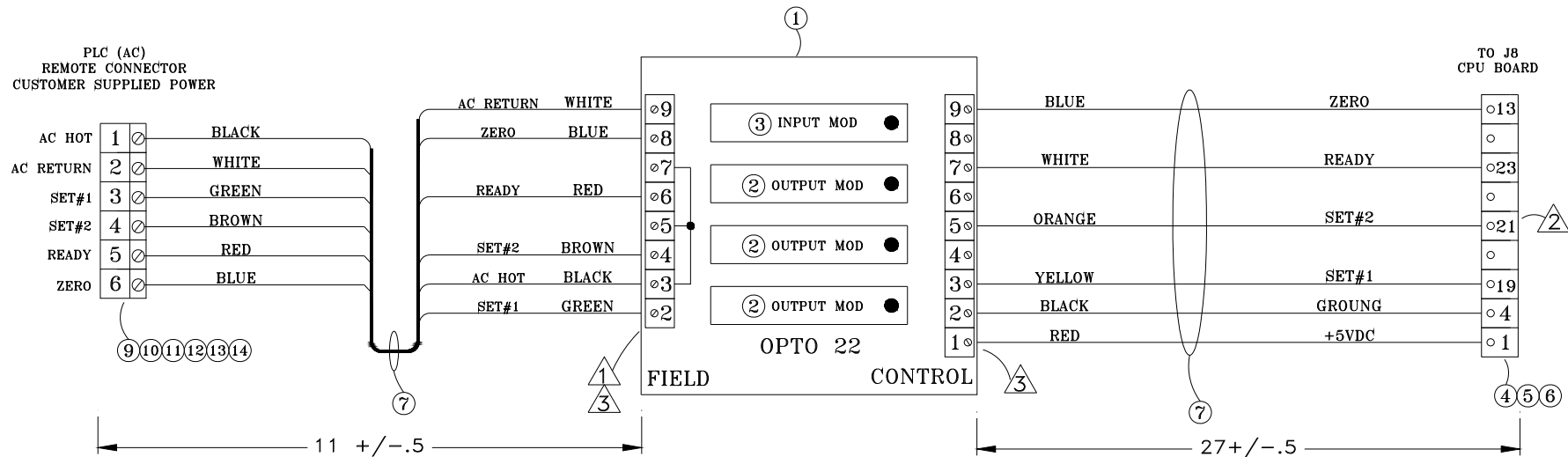

NOTES:

- ① SOLDER 22AWG JUMPER WIRE BETWEEN PINS 3,5 & 7 ON THE FIELD CONNECTOR. SOLDER TO THE BOTTOM OF THE PC BOARD, REMOVE ANY FLUX RESIDUE.
- ② INSTALL POLAR COVER (ITEM#5) TO ODD NUMBER PIN SIDE OF CONNECTOR.
- ③ INSTALL WIRE FERRULES (ITEM#8) FOR EACH TERMINATION TO RELAY BOARD.

ITEM	QTY	PART OR IDENTIFYING NO.	NOMENCLATURE OR DESCRIPTION	MATERIAL SPECIFICATIONS
PARTS LIST				
UNLESS OTHERWISE SPECIFIED DIMENSIONS ARE IN INCHES TOLERANCES ARE FRACTIONS DECIMALS ANGLES ± 1/64 .01 ± .01 ± 1/2° .xxx ± .005			CUSTOMER	
MATERIAL			VACUUM INSTRUMENT CORP. ROCKY HILL, N.Y. 11779	
FINISH UNLESS OTHERWISE SPECIFIED 125			Option, PLC Interface (A/C), MD490S	
NEXT ASSY	USED ON	APPROVALS	DATE	SIZE DWG. NO
		DRAWN <i>MAX</i>	6/2000	B 918-502
		CHECKED		REV. -
		PRODUCTION		FILE # 918-502-
		ENGINEERING		SHEET 1 OF 1
APPLICATION	DO NOT SCALE DRAWING	SCALE =	FILE # 918-502-	SHEET 1 OF 1

DWG. NO. REV. SH

THIS DRAWING IS FURNISHED FOR INFORMATION AND REFERENCE ONLY. THE FURNISHING OF THIS DRAWING DOES NOT CONVEY ANY REPRODUCTION OR MANUFACTURING RIGHTS.

REVISIONS			
REV.	DESCRIPTION	DATE	APPROVED

PLC (D\C)  
REMOTE CONNECTOR  
CUSTOMER SUPPLIED POWER

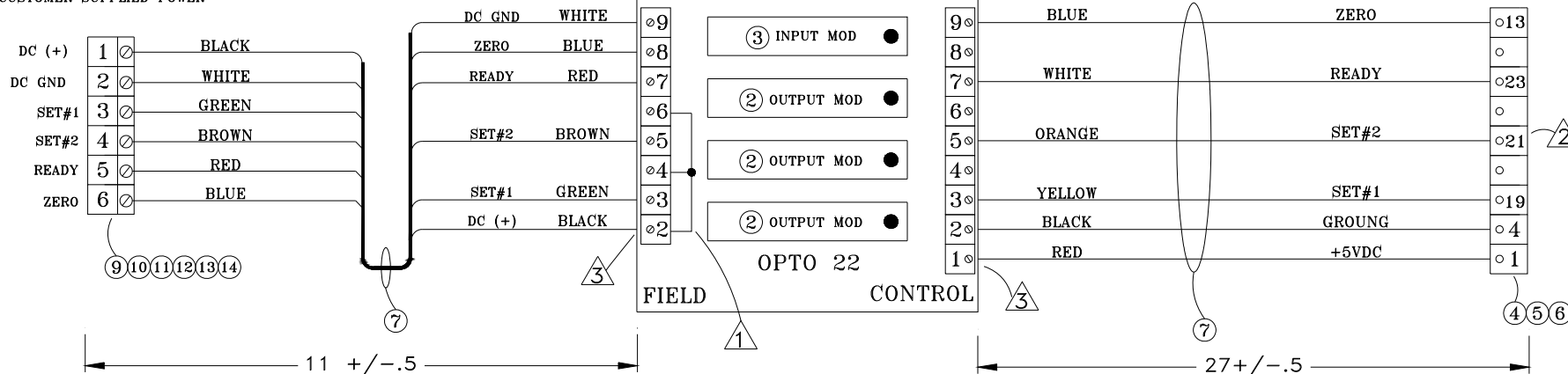

## NOTES:

- ① SOLDER 22AWG JUMPER WIRE BETWEEN PINS 2,4&6 ON THE FIELD CONNECTOR. SOLDER TO THE BOTTOM OF THE PC BOARD, REMOVE ANY FLUX RESIDUE.
- ② INSTALL POLAR COVER (ITEM#5) TO ODD NUMBER PIN SIDE OF CONNECTOR.
- ③ INSTALL WIRE FERRULES (ITEM#8) FOR EACH TERMINATION TO RELAY BOARD.

ITEM	QTY	PART OR IDENTIFYING NO.	NOMENCLATURE OR DESCRIPTION	MATERIAL SPECIFICATIONS
PARTS LIST				
UNLESS OTHERWISE SPECIFIED DIMENSIONS ARE IN INCHES. TOLERANCES ARE: FRACTIONS ± 1/64    DECIMALS .01 ± .01    ANGLES xxx ± .005 ± 1/2°			CUSTOMER	
MATERIAL			APPROVALS	
FINISH UNLESS OTHERWISE SPECIFIED 125			DATE	
NEXT ASSY			DRAWN <i>MARX</i> 10/00	
USED ON			CHECKED	
APPLICATION			PRODUCTION	
DO NOT SCALE DRAWING			ENGINEERING	
SIZE B		DWG. NO. 918-503		REV. -
SCALE =		FILE # 918-503-		SHEET 1 OF 1



**VACUUM INSTRUMENT CORP.**  
RONKONKOMA, N.Y. 11779

Option, PLC Interface  
(D\C), MD490S

DWG. NO. SH. REV.



